

# Nowcasting geomagnetically induced currents in power systems and pipelines based on ground magnetic field data

*Antti Pulkkinen, Ari Viljanen, Olaf Amm, and  
Risto Pirjola*

Finnish Meteorological Institute  
Helsinki, Finland

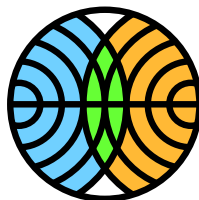

# Contents

- General.
- Leading principles of the GIC modeling.
- Computation of the geoelectric field.
- Computation of GIC.
- Real-time application of the modeling machinery.
- Summary and future.

# General

- Geomagnetically induced currents (GIC) are at the end of the space weather chain.

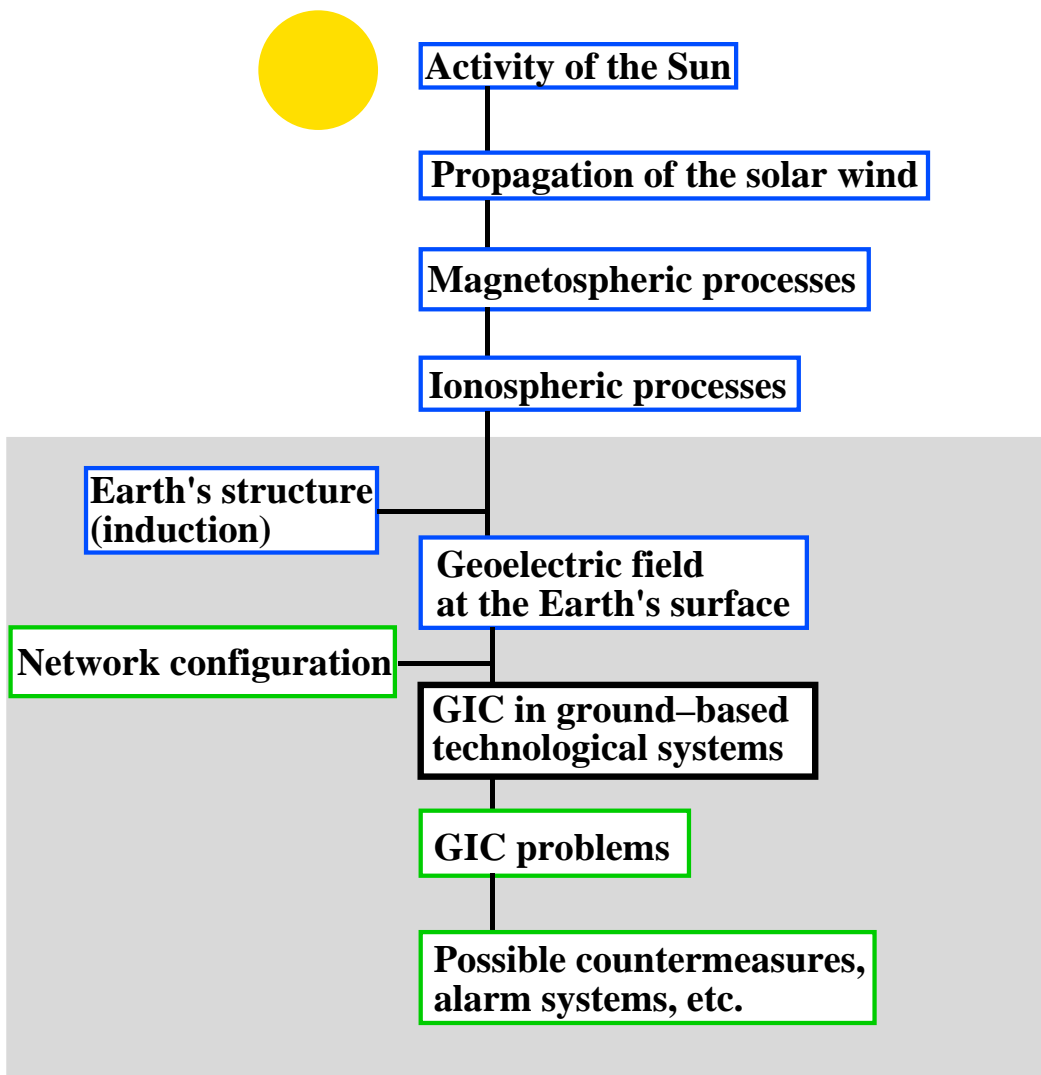

Figure 1: Space weather chain.

- GIC research in Finland since 1970's (see Fig. 2):
- Modeling of GIC in power systems and pipelines.
- Modeling of the geoelectric field.
- GIC measurements.

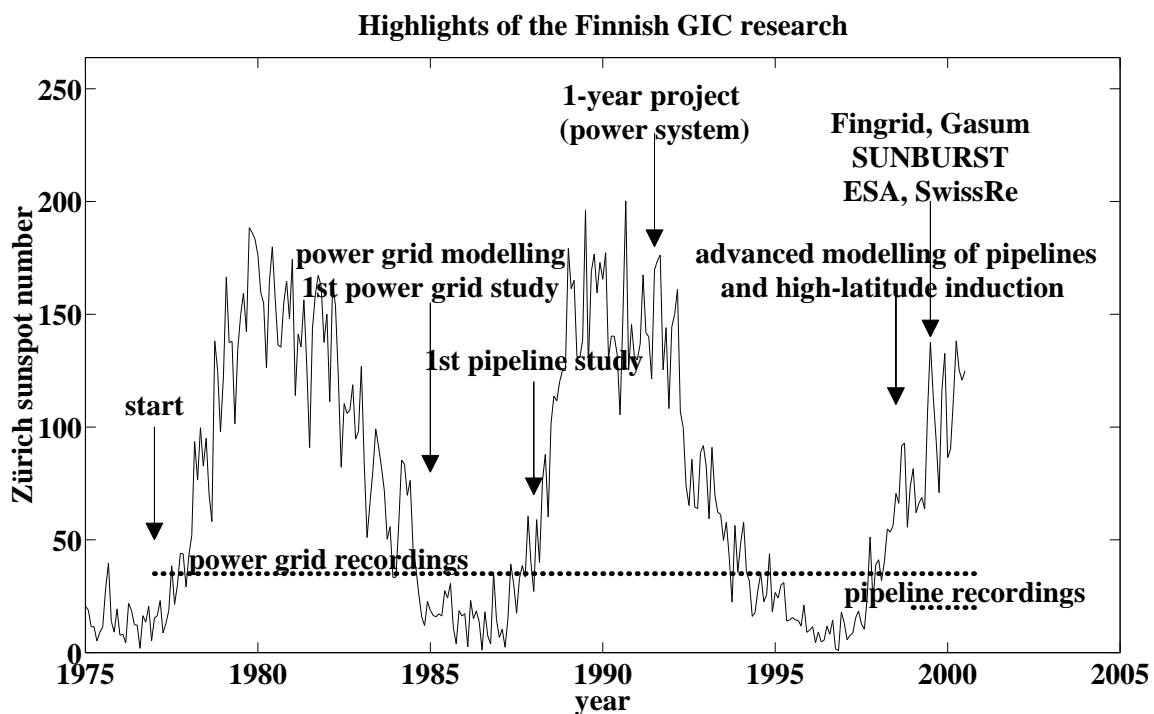

Figure 2: Highlights of the Finnish GIC research.

# Leading principles of GIC modeling

- Inductive coupling between GIC and the geoelectric field neglected due to low frequencies ( $< 1$  Hz).
- Modeling divided into two independent steps:
  - a) *Geophysical step*, i.e. computation of the surface geoelectric field. Geomagnetic induction problem handled typically in frequency domain.
  - b) *Engineering step*, i.e. computation of GIC driven by the known geoelectric field. Handled as a DC problem.

# Computation of the geoelectric field

- Information needed:
  - a) Ground conductivity structure.
  - b) Ionospheric current system  $\mathbf{j}(\mathbf{r}, t)$  or ground magnetic field variations  $\mathbf{B}(\mathbf{r}, t)$ .
- In the present work, ground magnetic field is used.
- Magnetic field is interpolated using the spherical elementary current system (SECS) method (Amm and Viljanen , 1999; Pulkkinen et al. , 2002).

In the SECS method, ionospheric equivalent currents are derived from the ground magnetic data using divergence-free elementary systems placed to the ionospheric height. Using the elementary systems, the magnetic field, always fulfilling

the  $\nabla \cdot \mathbf{B} = 0$  condition, can be computed anywhere at the surface of the Earth.

- In general, the relation between the horizontal ground magnetic and electric field components can be expressed as (e.g., Dmitriev and Berdichevsky , 1979):

$$E_{x,y}(x, y, \omega) = \pm \int_S G_Z(x, y, x', y', \omega) B_{y,x}(x', y', \omega) dx' dy' \quad (1)$$

where the spatial filter  $G_Z$  is the space domain counterpart of the wavenumber-dependent surface impedance.

- $G_Z$  in Eq, (1) is quite local. If the spatial variations of the ground magnetic field are assumed to be relatively small (or linear) within the effective region of  $G_Z$ , relation (1) simplifies to a local estimate

$$E_{x,y}(x, y, \omega) = \pm \frac{Z(x, y, \omega)}{\mu_0} B_{y,x}(x, y, \omega) \quad (2)$$

where  $Z(x, y, \omega)$  is the local surface impedance at the point  $(x, y)$  at the Earth's surface.

- In the most simple case, where the ground electrical conductivity is assumed to be uniform, we have

$$Z(\omega) = \sqrt{-\frac{i\omega\mu_0}{\sigma}} \quad (3)$$

where  $\sigma$  can be interpreted as a effective conductivity of the region considered.  $\sigma$  can be selected for each region separately and thus it is in principle  $(x, y)$ -dependent. It is simple to transform Eq. (2) with (3) to the time domain.

## Computation of GIC

- Information needed:
  - a) Surface geoelectric field  $\mathbf{E}(x, y, t)$ .
  - b) DC parameters and the topology of the technical conductor system under investigation.
- Modeling of systems having discrete groundings (power systems) (Lehtinen and Pirjola , 1985):

$$\mathbf{I} = (1 + \mathbf{YZ})^{-1} \mathbf{J} \quad (4)$$

$$J_i = \sum_{j \neq i} \frac{V_{ji}}{R_{ji}} \quad (5)$$

$$V_{ij} = \int_i^j \mathbf{E} \cdot d\mathbf{r} \quad (6)$$

where  $\mathbf{Y}$ ,  $\mathbf{Z}$  and  $R_{ij}$  define the electrical characteristics of the system and  $V_{ij}$  is the geovoltage between the grounding points. The integration in (6) is carried out along

the conductor between points  $i$  and  $j$ . Eqs. (5) and (5) are basically Kirchoff's and Ohm's laws, respectively.

- Modeling of systems having continuous groundings (pipelines) (Pulkkinen et al. , 2001b):

$$Y^{-1} \frac{d^2 I(x)}{dx^2} - Z I(x) = -E(x) \quad (7)$$

$$U(x) = -Y^{-1} \frac{dI}{dx} \quad (8)$$

where  $Z$  and  $Y$  again define the electrical characteristics of the system.  $E$  is now the geoelectric field component along the pipeline. Eq. (7) describes a transmission line in which voltage sources are distributed along the line, i.e. a continuously grounded system is approximated as a transmission line.

## Realtime application of the modeling machinery

- General nowcasting procedure shown in Fig. 4
- GIC in the Finnish pipeline are modeled (see Fig. 3). Actual nowcasting will be started during the pilot project proposed by FMI to ESA.
- Real-time data from the Nurmijärvi Geophysical Observatory located in the vicinity of Mäntsälä are used to compute the geoelectric field via Eq. (2). Due to the small size of the pipeline network, assumption about the homogeneity of the geoelectric field is reasonable.
- Distributed source transmission line model (Eqs. (7) and (8)) is used to compute GIC and pipe-to-soil voltages along the pipeline.
- Benchmarking

In Fig. 5, the measured and modeled GIC are compared for the "Bastille day" event on July 15, 2000.

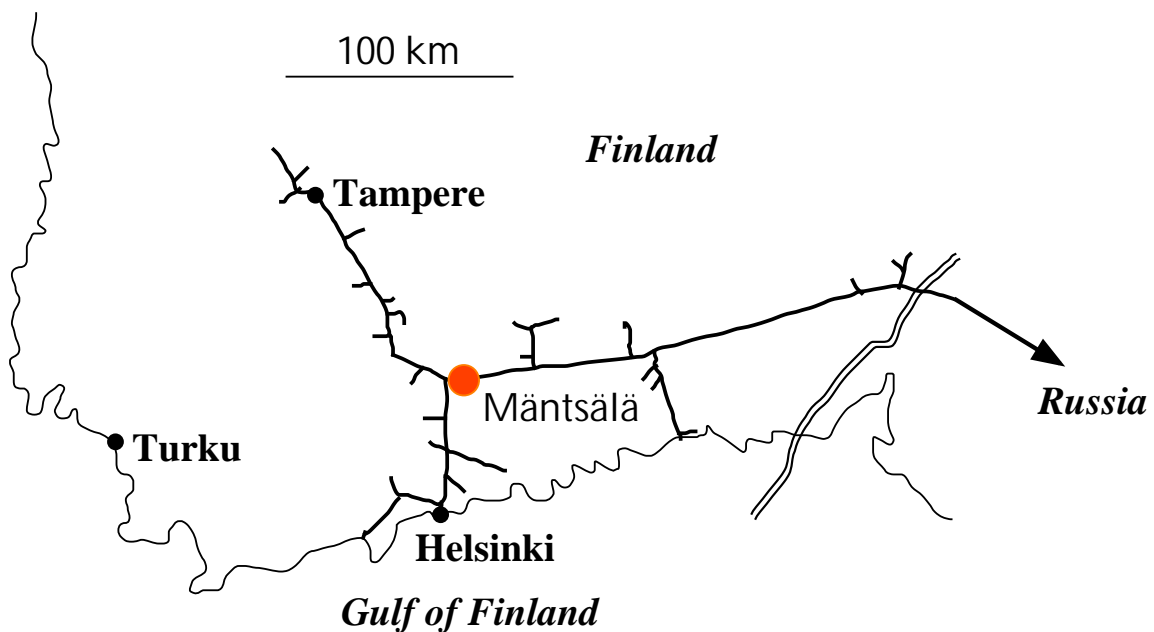

Figure 3: Finnish natural gas pipeline system in 2000. GIC has been recorded in co-operation between the Gasum company and the Finnish Meteorological Institute at Mäntsälä since November 1998 (Pulkkinen et al. , 2001a).

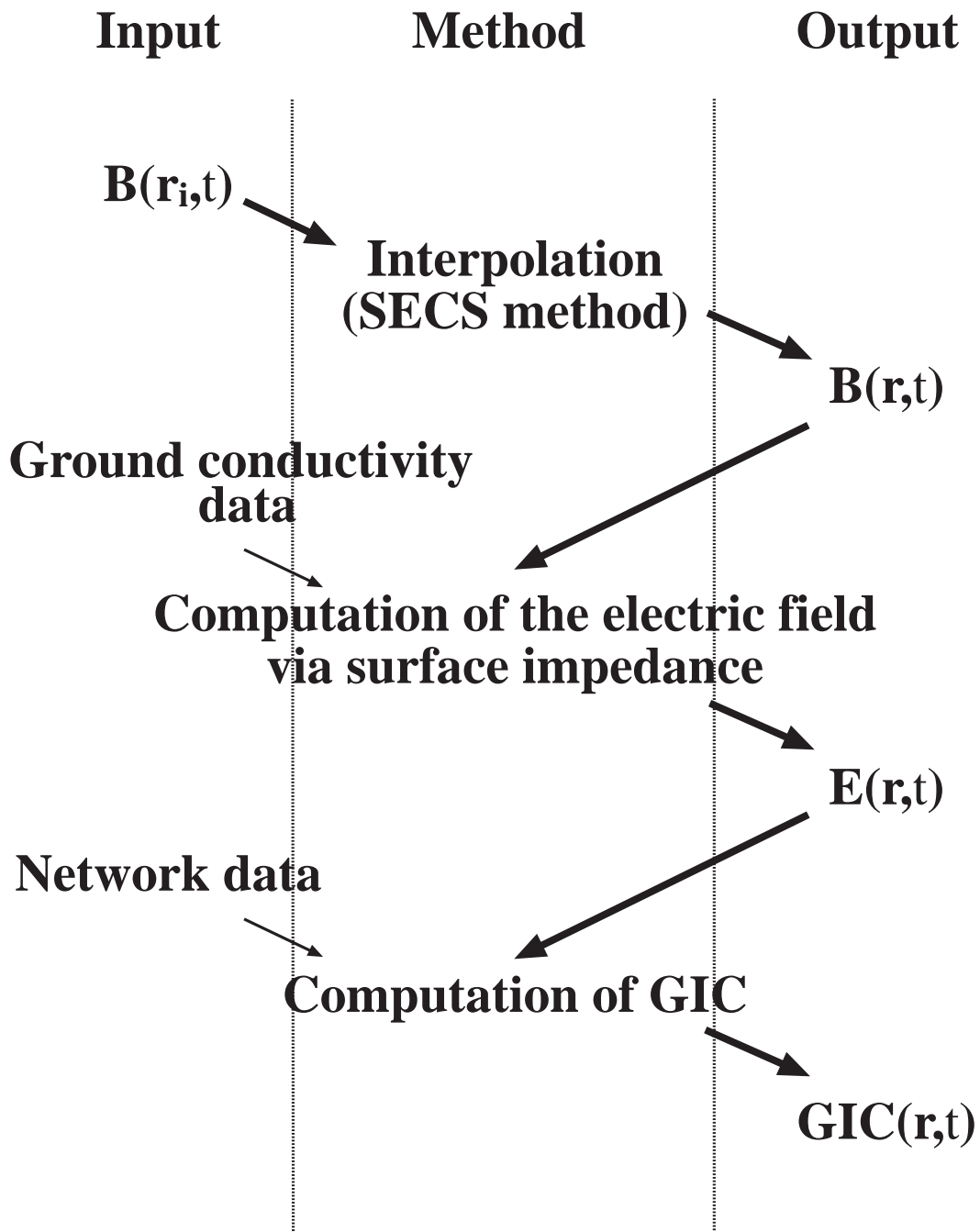

Figure 4: General procedure for GIC nowcasting.

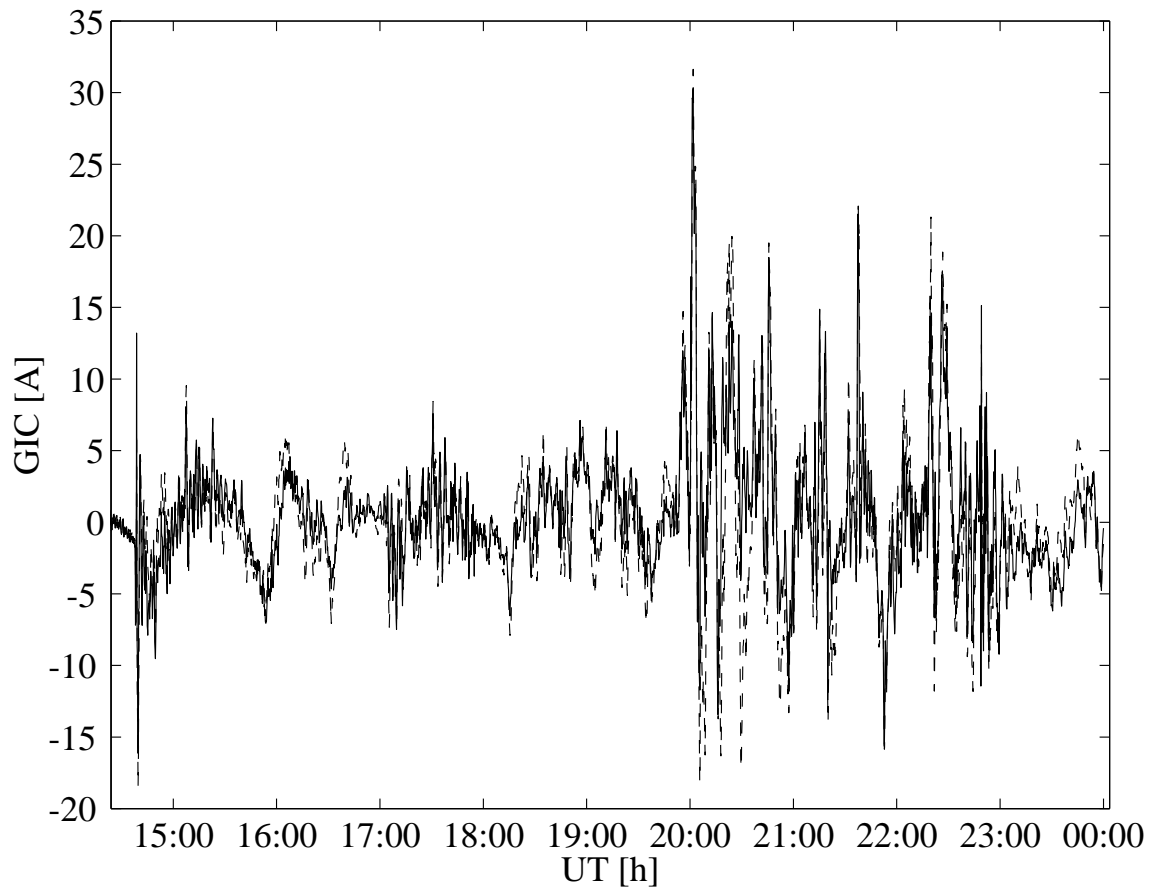

Figure 5: Measured (solid) and modeled (dashed) GIC in the Finnish natural gas pipeline at Mäntsälä during the "Bastille day" event on July 15, 2000.

## Summary and future

- GIC is modeled in two independent steps: geophysical and engineering steps.
- Geoelectric field is computed from magnetic data via the surface impedance.
- Real-time access to magnetic data enables GIC nowcasting.
- GIC has to be modeled differently for systems having discrete and continuous groundings.
- The same techniques can be easily applied to any network and are applicable also for forecasting purposes. These techniques are used in three pilot projects proposed to ESA.

## References

Amm, O., and A. Viljanen, Ionospheric disturbance magnetic field continuation from the ground to ionosphere using spherical elementary current systems, *Earth, Planets and Space*, **51**, 431, 1999.

Dmitriev, V., and M. Berdichevsky, The fundamental model of magnetotelluric sounding, *Proceedings of the IEEE*, **67**, July 1979.

Lehtinen, M., and R. Pirjola, Currents produced in earthed conductor networks by geomagnetically-induced electric fields, *Annales Geophysicae*, **3**, 479, 1985.

Pulkkinen, A., A. Viljanen, K. Pajunpää, and R. Pirjola, Recordings and occurrence of geomagnetically induced currents in the Finnish natural gas pipeline network, *J. Appl. Geophys.*, **48**, 219, 2001a.

Pulkkinen, A., R. Pirjola, D. Boteler, A. Viljanen, and I. Yegorov, Modelling of space weather effects on pipelines, *Journal of Applied Geophysics*, **48**, 233, 2001b.

Pulkkinen, A., O. Amm, A. Viljanen, and BEAR Working Group, Ionospheric equivalent current distributions determined with the method of spherical elementary current systems, Accepted for publication in *Journal of Geophysical Research*, 2002.

contacts: antti.pulkkinen@fmi.fi, ari.viljanen@fmi.fi,  
olaf.amm@fmi.fi, risto.pirjola@fmi.fi