

# **Space Weather Prototype System**

**ESWS-BIR-TN-0001**

M. Kruglanski, D. Heynderickx

*BIRA/IASB*

**November 2001**

# Introduction

This document is intended to be a user guide to the space weather prototype developed by BIRA/IASB for the ESA Space Weather Study (ESWS) (ESTEC Contract No. 14069/99/NL/SB).

The first part of the document contains a short overview of the prototype components. The main body of the text consists of a series of screenshots of the prototype Web pages that illustrate the capabilities of the tool and guide the user through the system. The document concludes with a summary of the status of the project.

On the screenshots in the following pages, icons have been added to illustrate the logical flow between the various related pages. The main icon is a block arrow that points from a hyperlink or a button to the next page that is produced by the prototype as a result of the action. When parts of several screenshots are reproduced on a page, the connection between the screens are indicated by means of blue arrows. Finally, red ovals draw attention to specific features of user inputs.



# System overview

The prototype is built on three levels:

- Level 1: Yellow pages
- Level 2: Data retrieval and model runs
- Level 3: Parameter retrieval

## **Level 1: Yellow pages**

The Space Environment Yellow Pages (SWYPs) are a compilation of services, accessible through Internet, that provide useful resources to reconstruct the space environment at a particular location and time.

The SWYPs include cross-referenced catalogues of references to institutions maintaining servers with space environment data and/or models, descriptions of satellite or ground missions related to the measurements of environment components, and parameters and physical quantities acting on the environment. The SWYPs also include information needed to retrieve and access the referenced data. The interface to the SWYPs is a set of dynamic HTML pages that generate (through PHP) database queries and present the query results. Different access routes are available, e.g. starting from a list of physical parameters or of satellite missions.

More information on the organisation of the yellow pages is given in the annex.

## **Level 2: Data retrieval and model runs**

The data retrieval makes use of automatic queries generated by a script. Consequently, only resources that support the following access protocols have been implemented:

- FTP;
- HTTP, except when multiple queries are required;
- automatic delivery by e-mail.

The retrieved data are presented to the user in flat ASCII files containing a descriptive header and a simple column layout. When the spacecraft ephemeris is available, it is retrieved and added to the result files.

Resources in the form of models (such as trapped radiation models) can be added: in this study, the models will run locally at BIRA for demonstration purposes. The models are evaluated along an orbit selected by the user.

## **Level 3: Parameter retrieval**

In step 3, the user interface will be extended to allow the user to input an orbit description, a description of the needed physical parameters, and the time frame. The interface will then present the user with first selection of resources from the SWYPs, with the option of refining or re-defining the query.

## **Case studies**

As a demonstration, the tool has been applied to a post analysis of a case study, which has been selected from four scenarios that were drafted by FMI (see ESWS-FMI-WP433: *Testing using scenarios with space weather events*). The results of the analysis are presented as an interactive Web page ([http://eve.oma.be/ESWS/case\\_study/](http://eve.oma.be/ESWS/case_study/)).

# Starting point

ESA Space Weather Programme - Netscape

BIRA/IASB, MK, 2000/09/13

## ESA Space Weather Programme

The European Space Agency is funding two parallel studies of an ESA Space Weather Programme. The Belgian Institute for Space Aeronomy is sub-contractor of the study lead by the Rutherford Appleton Laboratory. This web site is dedicated to the space weather prototyping activity (WP 434).

### Space Weather Prototyping Activity



- Contact: Dr. D. Heynderickx ([d.heynderickx@oma.be](mailto:d.heynderickx@oma.be))
- Demonstration pages
  - [Registration form](#)
  - [Help pages](#) (out of date)
  - [Level 1](#) — Main entry point
  - [User contribution centre](#)
  - [Level 2](#) — [Level 3](#)
  - [Data retrieval centre](#) — >> [Remove old data](#)
- Externals
  - [Interface to NASA AE-8/AP-8 models](#)
  - [Interface to AFRL CRRES/PRO model](#)
  - [Interface to the atmospheric model MSISE](#)
- [Post-event analysis](#) <sup>New</sup>
- [Software documentations](#) (local access)

### Additional Links

- [Space weather study main page](#) at RAL
- [ESA's Space Environments and Effects Analysis Section](#)
- [Space Environment Information System](#)
- [SPEE Space weather server](#) at FMI

### Legal Notice

Some of the information included on this web site is confidential and restricted to members of the study team or of the ESA staff.

 The Institute is part of the Prime Minister's Services through the Federal Office for Scientific, Technical and Cultural Affairs. 

# **Level 1**

## **Yellow pages**

# « Where can I find help on the system? »

Context-sensitive  
help

SWYP Help pages - Netscape

Michael Kruglanski

## SWYP Help pages

The European Space Agency is funding two parallel studies of an ESA Space Weather Programme. This web site is dedicated to the space weather prototyping activity (WP 434) of the study lead by the Rutherford Appleton Laboratory.

### Table of contents

- SWYP Tutorial**  
*to learn about the system, how to use it, ...*
- SWYP Documentation pages**  
*to access to the manual pages of each SWYP catalogues*  
[ [Space or ground missions](#), [Models or sensors](#), [Parameters or indices](#), [Data services](#), ...]
- SWYP Frequently Asked Questions**  
*to get assistance during your first steps*
- Links to other resources**  
*to find more information elsewhere on the web*

**Legal notice**

Some of the information included on this web site is confidential and restricted to members of the study team or of the ESA staff.

**Contact**

Dr. D. Heynderickx

© BIRA/IASB, last update: 2000-Dec-15

Catalogue  
overview

# « Where can I find help on the system? »

[Catalogue overview](#)

The information included in the *Space Weather Yellow Pages* is organized into several catalogues.

```
graph TD; SE_Space[SE Space or ground missions] --> SE_Models[SE Models or sensors]; SE_Data[SE Data services] --> SWYP_Source[SWYP Source files]; SWYP_Source --> SWYP_Channel[SWYP Channel catalogue]; YP_Meta[YP Meta-parameters] --> SE_Parameters[SE Parameters or indices]; YP_Data[YP Data-type components] --> SE_Parameters; YP_Data --> Data_Types[Data types (support catalogue)]; SE_Parameters --> SE_Models; SE_Parameters --> Data_Types; Data_Types --> SE_Parameters;
```

© BIRA/IASB, last update: 2000-Dec-15

« I am looking for information on the SOHO spacecraft and onboard instruments. »

SWYP Browsing - Netscape

Michel Krughavala

### SWYP Browsing

SE Space or ground missions

Entry: SOHO

<b>Description</b>	Solar and Heliospheric Observatory mission
<b>ESA Project Scientist</b>	Dr. B. Fleck (bfleck@esa.nascom.nasa.gov)
<b>Institute or centre</b>	ESA Solar System Division
<b>Web site</b>	sohowww.estec.esa.nl/
<b>Address</b>	Mail Code 682.3 Goddard Space Flight Center Greenbelt MD 20771 USA
<b>General reference</b>	SOHO Science Operations Plan, V. Domingo, A. Poland and B. Fleck, Issue 2.1, ESA S/95/088/972, March 1995
<b>More ...</b>	Look at the <a href="http://sohowww.estec.esa.nl/">sohowww.estec.esa.nl/</a> web site. Look in the NSSDC <a href="#">Master Catalog</a> (1995-065A)

SE Models or sensors    SWYP Channel catalogue

Spacecraft ephemeris    Check the ephemeris tool    SSC Location Channels

Your workspace contains already 3 entries

© BIRA/IASB, last update: 2000-Nov-06

SE Models or sensors

« I am looking for information on the SOHO spacecraft and onboard instruments. »

The screenshot shows a web browser window titled "SWYP Browsing". The interface includes a search bar with the text "SE Models or sensors" and a search icon. Below the search bar, a green banner indicates "4 entries match your request". The search results are listed in a table:

Instrument Name	Action
SOHO Coronal Diagnostic Spectrometer	SWYP Channel catalogue
SOHO Comprehensive Suprathermal and Energetic Particle Analyser	SWYP Channel catalogue
SOHO Extreme Ultraviolet Imaging Telescope	SWYP Channel catalogue
SOHO Large Angle Spectroscopic Coronagraph	LASCO Instrument catalogue

At the bottom of the interface, there is a message: "Your workspace contains already 3 entries". The copyright notice at the bottom right reads: "© BIRALISE, last update: 2000-Nov-06".

« I am looking for information on the SOHO spacecraft and onboard instruments. »

**LASCO Instrument** →

**SWYP Browsing**

SE Models or sensors

Entry: **LASCO**

<b>Description</b>	SOHO Large Angle Spectroscopic Coronagraph LASCO includes three nested coronagraphs, C1, C2, and C3, that image the solar corona from 1.1-3, 1.5-6 and 3-30 solar radii, respectively. C1 is equipped with a Fabry-Perot interferometer
<b>Mission</b>	<a href="#">Solar and Heliospheric Observatory mission</a>
<b>Number of channels</b>	-1
<b>Time resolution</b>	360 seconds (or longer)
<b>Principal Investigator</b>	Dr. R. A. Howard ( <a href="mailto:howard@cronus.nrl.navy.mil">howard@cronus.nrl.navy.mil</a> )
<b>Institute or centre</b>	US Naval Research Laboratory
<b>Web site</b>	<a href="http://www.nrl.navy.mil/">www.nrl.navy.mil/</a>
<b>Address</b>	Code 7660 Washington DC 20375 USA
<b>General reference</b>	The Large Angle Spectroscopic Coronagraph (LASCO): Visible Light Coronal Imaging and Spectroscopy, G. E. Brueckner, et al., Proceedings of the First SOHO Workshop, ESA SP-348, pp. 27-34, 1992
<b>More...</b>	Look at the <a href="http://lasco-www.nrl.navy.mil">lasco-www.nrl.navy.mil</a> web site. Look in the NSSDC <a href="#">Master Catalog</a> (1995-065A)

→ **SWYP Channel catalogue** → **SE Parameters or indices** → **SWYP Source files**

Measured parameters →

« I am looking for information on the SOHO spacecraft and onboard instruments. »

Measured parameters

The screenshot shows the SWYP Browsing interface. At the top, there is a blue header with the text "SWYP Browsing" and several icons. Below the header is an orange bar with "SE Parameters or indices" and a search box. The main content area has a yellow background and displays the entry "CORONA". A table provides details about the entry, including its description, unit, valid range, type, and dependencies. Below the table is a green bar with four buttons: "SWYP Channel catalogue", "SE Models or sensors", "SE Space or ground missions", and "SWYP Source files". At the bottom of the green bar is a search box for SWYP channels in a restricted range of photon wave length, with input fields for "0.001" and "1000" [nm]. The interface also includes a footer with icons and the text "Your workspace contains already 3 entries" and a copyright notice "© BIRA/IASB, last update: 2000-Nov-06".

English

### SWYP Browsing

SE Parameters or indices

Entry: CORONA

<b>Description</b>	Solar corona radiance at 1 AU
<b>Unit</b>	$\text{mW sr}^{-1}$
<b>Valid range</b>	$1 \times 10^{-7} - 100 \text{ [mW sr}^{-1}\text{]}$
<b>Type</b>	<u>Image</u>
<b>Depends on</b>	<u>Photon wave length</u>
<b>More...</b>	No additional information available

SWYP Channel catalogue
  SE Models or sensors  
 SE Space or ground missions
  SWYP Source files

Search for SWYP channels in a restricted range of... Photon wave length:  -  [nm]

Your workspace contains already 3 entries

© BIRA/IASB, last update: 2000-Nov-06

# « Where can I find more information about the Ulysses spacecraft? »

The screenshot shows a Netscape browser window titled "SWYP Browsing - Netscape". The main content area displays information for the "Entry: ULYSSES" mission. A table provides details about the mission, including the project scientist, institute, website, and address. Below the table are several navigation buttons for related resources. Three callout boxes with arrows point to specific links:

- Search the WWW**: Points to the "EDIT" button in the top right of the entry section.
- Ulysses Web site**: Points to the "More..." section of the table, which contains the link [helio.estec.esa.nl](http://helio.estec.esa.nl).
- NSSDC Master Catalog**: Points to the link "Look in the NSSDC Master Catalog (1990-090B)" in the "More..." section.

<b>Description</b>	Ulysses mission
<b>Project Scientist</b>	Dr. K.-P. Wenzel (kwenzel@estec.esa.nl)
<b>Institute or centre</b>	European Space Research and Technology Centre
<b>Web site</b>	helio.estec.esa.nl/ulysses/welcome.html
<b>Address</b>	Space Science Dept. of ESA P.O. Box 299 2200 AG Noordwijk The Netherlands
<b>General reference</b>	The Ulysses mission, K.-P. Wenzel, et al., Astron. Astrophys. Suppl. Ser., 92, pp. 207, 1992
<b>More...</b>	Look at the <a href="http://helio.estec.esa.nl">helio.estec.esa.nl</a> web site. Look in the NSSDC Master Catalog (1990-090B)

Navigation buttons at the bottom of the interface include:

- SE Models or sensors
- SWYP Channel catalogue
- Spacecraft ephemeris
- Check the ephemeris tool
- SSC Location Channels

Footer: © BIRA/ASB, last update: 2000-Nov-06

# « Where can I find more information about the Ulysses spacecraft? »

The image displays three sequential screenshots of a Netscape browser window, illustrating a search process for information about the Ulysses spacecraft.

**Top Screenshot:** The browser window title is "AltaVista - Web Results for: Ulysses mission - Netscape". The address bar shows the URL "http://www.altavista.com/cgi-bin/query?q=Ulysses+mission". A yellow callout box with the text "Search the WWW" and an arrow points to the search bar. The search results page shows the AltaVista logo and a search bar containing "Ulysses mission".

**Middle Screenshot:** The browser window title is "Ulysses Mission - Netscape". The address bar shows the URL "http://helio.estec.esa.nl/ulysses/mission.html". A yellow callout box with the text "Ulysses Web site" and an arrow points to the browser window. The page content includes the heading "The Ulysses Mission" and the subtitle "Exploring Space over the Sun's Poles".

**Bottom Screenshot:** The browser window title is "NSSDC Master Catalog: Spacecraft - Netscape". The address bar shows the URL "http://nssdc.gsfc.nasa.gov/nmc/tmp/1990-090B.html". A yellow callout box with the text "NSSDC Master Catalog" and an arrow points to the browser window. The page content includes the heading "Ulysses" and the NSSDC ID "1990-090B". Under the heading "Other Name(s)", there is a list item: "International Solar Polar Mission". A small photograph of the spacecraft is visible on the right side of the page.

# « What is the current location of the Cluster satellites? »

SWYP Browsing - Netscape

Michel Kruglanski SWYP Browsing

SE Space or ground missions

4 entries match your request

Cluster-II Tango (FM8 or SC4)	SE Models or sensors
Cluster-II Rumba (FM5 or SC1)	SE Models or sensors
Cluster-II Salsa (FM6 or SC2)	SE Models or sensors
Cluster-II Samba (FM7 or SC3)	SE Models or sensors

Your workspace contains already 3 entries

© BIRAJASE, last update: 2000-Nov-06

Ephemeris tool for Salsa

# « What is the current location of the Cluster satellites? »

[Ephemeris tool for Salsa](#)

**Ephemeris Tool**

Cluster-II Salsa (FM6 or SC2)

<b>NORAD TLE</b>	1 264220 000420 03292.50555555 .00000000 00000-0 00000-0 0 0000 2 26422 09.0220 160.5993 0501030 5.0070 550.4145 1.42020344 518
<b>TLE Epoch</b>	20 Oct 2001 13:59:59
<b>Inclination</b>	89.02 [deg]
<b>Eccentricity <math>e_0</math></b>	0.65040
<b>Mean motion <math>n_0</math></b>	0.42 [rev/day] = 2.64071 [rad/day]
<b>Evaluation on 20 Oct 2001 13:59:59</b>	
<b>Age of extrapolation</b>	-0.00 [day]
<b>Perigee, apogee</b>	19941.1 – 117871.1 [km]
<b>Right ascension of the ascending node</b>	162.40 [deg]
<b>Argument of perigee</b>	5.81 [deg]
<b>True anomaly</b>	350.54 [deg]
<b>GEI Location</b>	x: -25162.4, y: 8012.6, z: -1685.3 [km]
<b>Velocity</b>	17940.9 [km/h] = 4.984 [km/s]

SPENVIS Orbit Generator  1 day

© BIRA/IASB, last update: 2000-Nov-19

[Run the SPENVIS orbit generator](#)

# « What is the current location of the Cluster satellites? »

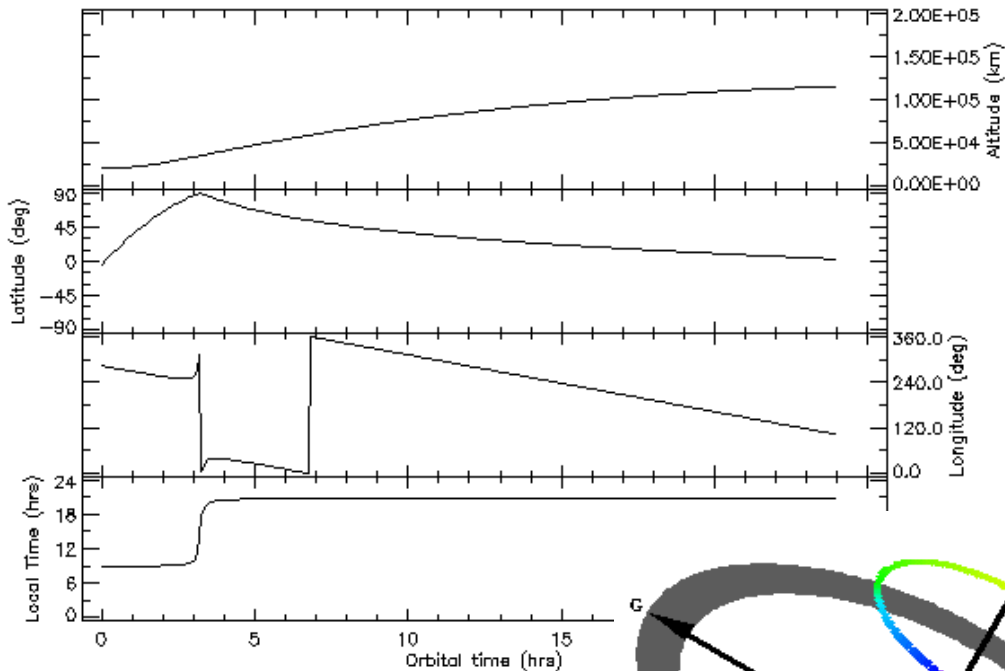

Run the SPENVIS orbit generator

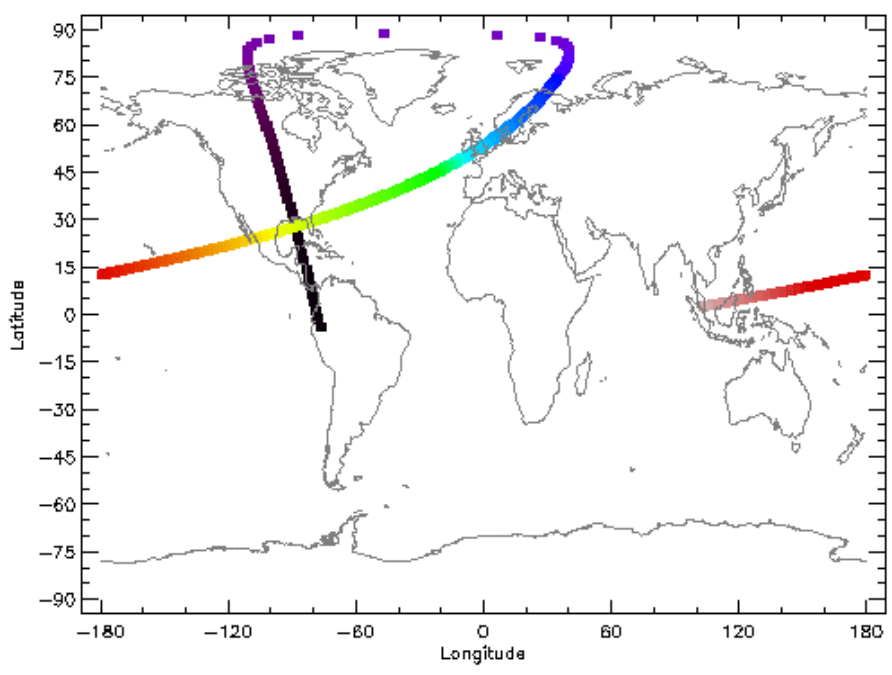
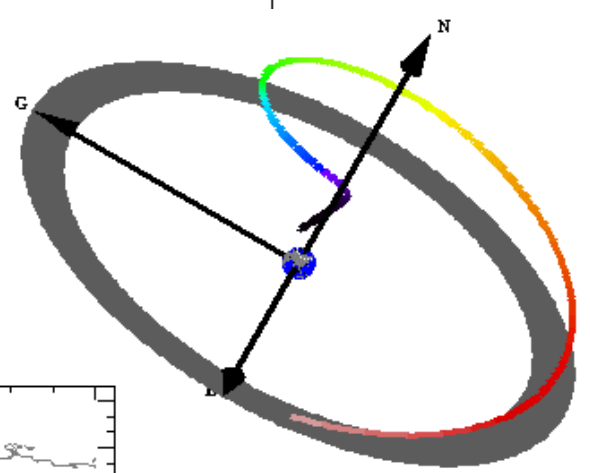

« I am looking for information on the SOPA particle analyser onboard the LANL 1994-084 satellite. »

SWYP Browsing - Netscape

Michel Knauth SWYP Browsing

SE Models or sensors

Entry: SOPA

<b>Description</b>	LANL 1994-084 Synchronous Orbit Particle Analyzer The SOPA instrument consists of three solid state detector telescopes accepting particles from three different directions relatively to the spacecraft spin axis. Each telescope consists of a collimator, a thin front detector, a thick back detector and a surrounding high and low Z passive shielding.
<b>Mission</b>	Los Alamos (LANL) geosynchronous satellite 1994-084
<b>Number of channels</b>	30
<b>Time resolution</b>	0.16 seconds (or longer)
<b>Principal Investigator</b>	Dr. R. D. Belian (rdbelian@lanl.gov)
<b>Institute or centre</b>	Los Alamos National Laboratory
<b>Web site</b>	www.lanl.gov/orgs/nis/
<b>Address</b>	NIS-2 Mail Stop D436 Los Alamos NM-87545 USA
<b>General reference</b>	High-Z Energetic Particles at Geostationary Orbit During the Great Solar Proton Event Series of October 1989, Belian, R. D., G. R. Gisler, T. Cayton, and R. Christensen, J. Geophys. Res., 97, 16897, 1992
<b>More...</b>	Look at the <a href="http://leadbelly.lanl.gov">leadbelly.lanl.gov</a> web site. You may also check at <a href="http://NSSDC">NSSDC</a>

SWYP Channel catalogue SE Parameters or indices SWYP Source files

[List of channels](#)

[Measured parameters](#)

« I am looking for information on the SOPA particle analyser onboard the LANL 1994-084 satellite. »

SWYP Browsing - Netscape

Michel Kruglinski SWYP Browsing

SE Parameters or indices

2 entries match your request

Unidirectional differential electron flux	SWYP Channel catalogue
Unidirectional differential proton flux	SWYP Channel catalogue

Your workspace contains already 3 entries

© BIRAFIASE, last update: 2000-Nov-06

Measured parameters

« I am looking for information on the SOPA particle analyser onboard the LANL 1994-084 satellite. »

SWYP Browsing - Netscape

Michel Krugler SWYP Browsing

SWYP Channel catalogue

Too many entries match your request: (19)  
You can refine your request or look at the first matching entries.

Refine your request

Only the 10 first matching entries are listed below.

Eud_flux_none <Sopa@1994-084> (Sopa1994084_txt#5)	0
Eud_flux_none <Sopa@1994-084> (Sopa1994084_txt#6)	1
Eud_flux_none <Sopa@1994-084> (Sopa1994084_txt#7)	2
Eud_flux_none <Sopa@1994-084> (Sopa1994084_txt#8)	3
Eud_flux_none <Sopa@1994-084> (Sopa1994084_txt#9)	4
Eud_flux_none <Sopa@1994-084> (Sopa1994084_txt#10)	5
Eud_flux_none <Sopa@1994-084> (Sopa1994084_txt#11)	6
Eud_flux_none <Sopa@1994-084> (Sopa1994084_txt#12)	7
Eud_flux_none <Sopa@1994-084> (Sopa1994084_txt#13)	8
Pud_flux_none <Sopa@1994-084> (Sopa1994084_txt#14)	9

© BIRA/LASB, last update: 2000-Nov-06

Channel data

List of channels

« I am looking for information on the SOPA particle analyser onboard the LANL 1994-084 satellite. »

Channel data → SWYP Browsing

SWYP Channel catalogue

Entry 97 := Eud\_flux\_none <Sopa@1994-084> (Sopa1994084\_txt#8) EDIT

<b>Sensor or detector</b>	<a href="#">LANL 1994-084 Synchronous Orbit Particle Analyzer</a>
<b>Mission</b>	<a href="#">Los Alamos (LANL) geosynchronous satellite 1994-084</a>
<b>Measured quantity</b>	<a href="#">Unidirectional differential electron flux</a> cm <sup>-2</sup> sr <sup>-1</sup> keV <sup>-1</sup> s <sup>-1</sup> - ( <a href="#">Scalar data</a> )
<b>Electron energy</b>	150 – 225 [keV]
<b>Source file</b>	<a href="#">1-minute 1994-084 LANL Synchronous Orbit Particle Analyzer Data</a> [LANL Geosynchronous energetic particles data request system]

Similar channels for the same sensor    
 Similar channels for other sensors  
 Similar channels for other missions    
 Other channels from the same source file

Your workspace contains already 3 entries

© BIRA/IASB, last update: 2000-Nov-06

# « Where can I find data from the EPAM instrument onboard ACE? »

SWYP Browsing - Netscape

Michel Kruglovski **SWYP Browsing**

SWYP Source files

Entry: ACE\_EPAM\_1H\_TXT

<b>Description</b>	Hourly Averaged ACE Differential Electron and Proton Flux (ascii file)
<b>Provider</b>	Space Environment Center anonymous FTP system (SEC)
<b>Generic URL</b>	ftp://ftp2.sec.noaa.gov/pub/lists/ace2/ yyyymm_ace_epam_1h.txt
<b>Accessibility period</b>	from 24 Jan 1999 until today
<b>Time resolution</b>	1:00:00 hours (or longer)
<b>Number of columns</b>	16
<b>More ...</b>	<a href="#">Search the web</a>

SWYP Channel catalogue SE Parameters or indices Retrieved data files

Your workspace contains already 3 entries

© BIR/IASB, last update: 2000-Nov-06

# « Where can I find data from the EPAM instrument onboard ACE? »

SEC FTP site

Current directory is /pub/lists/ace2

ftp2.sec.noaa.gov McFTPd Server (licensed copy) ready.  
This anonymous ftp server is provided by the U.S.  
Department of Commerce, NOAA, Space Environment Center.

NOTICE TO USERS: Use of this system constitutes consent  
to security monitoring and testing. All activity is  
logged with your IP address.

SEC operates two redundant ftp servers;  
ftp.sec.noaa.gov and ftp2.sec.noaa.gov

If you have problems please contact us via email at  
sec@sec.noaa.gov.  
You are user #5 of 50 simultaneous users allowed.

The Space Environment Center anonymous ftp server  
provides recent solar-geophysical data in the form  
of reports, summaries, lists, plots, and images.

On login change to the public (pub) directory:  
ftp> cd pub

Check SECNEWS.txt for notices, changes, and announcements.

Up to higher level directory

Filename	Size	Date	Type
<a href="#">200009 ace epam lh.txt</a>	82 Kb	Sun Oct 01 00:00:00 2000	Plain Text
<a href="#">200009 ace loc lh.txt</a>	43 Kb	Sat Sep 30 00:00:00 2000	Plain Text
<a href="#">200009 ace mag lh.txt</a>	61 Kb	Sun Oct 01 00:00:00 2000	Plain Text
<a href="#">200009 ace sis lh.txt</a>	49 Kb	Sun Oct 01 00:00:00 2000	Plain Text
<a href="#">200009 ace sweepam lh.txt</a>	52 Kb	Sun Oct 01 00:00:00 2000	Plain Text
<b><a href="#">200010 ace epam lh.txt</a></b>	<b>85 Kb</b>	<b>Wed Nov 01 00:00:00 2000</b>	<b>Plain Text</b>
<a href="#">200010 ace loc lh.txt</a>	44 Kb	Tue Oct 31 00:00:00 2000	Plain Text
<a href="#">200010 ace mag lh.txt</a>	63 Kb	Wed Nov 01 00:00:00 2000	Plain Text
<a href="#">200010 ace sis lh.txt</a>	50 Kb	Wed Nov 01 00:00:00 2000	Plain Text
<a href="#">200010 ace sweepam lh.txt</a>	53 Kb	Wed Nov 01 00:00:00 2000	Plain Text
<a href="#">200011 ace epam lh.txt</a>	82 Kb	Fri Dec 01 00:00:00 2000	Plain Text
<a href="#">200011 ace loc lh.txt</a>	43 Kb	Thu Nov 30 00:00:00 2000	Plain Text
<a href="#">200011 ace mag lh.txt</a>	61 Kb	Fri Dec 01 00:00:00 2000	Plain Text
<a href="#">200011 ace sis lh.txt</a>	49 Kb	Fri Dec 01 00:00:00 2000	Plain Text

# « What data is accessible at NOAA Space Environment Center? »

SWYP Browsing - Netscape

Michel Knaflitz

## SWYP Browsing

SE Data services

Entry: SECFTP

<b>Description</b>	Space Environment Center anonymous FTP system
<b>Manager</b>	E. Hildner
<b>Contact</b>	Mrs. V. Raben (vraben@sec.noaa.gov)
<b>Institute or centre</b>	SEC: NOAA Space Environment Center
<b>Web site</b>	<a href="http://www.sec.noaa.gov/">www.sec.noaa.gov/</a>
<b>Address</b>	Code E/GC2 325 Broadway Boulder CO 80303-3328 USA
<b>Method</b>	File transfer protocol
<b>More...</b>	Look at the <a href="http://ftp.sel.noaa.gov">ftp.sel.noaa.gov</a> ftp site.

SWYP Source files    SWYP Channel catalogue

Your workspace contains already 3 entries

© BIRA/IASB, last update: 2000-Nov-06

Source files

# « What data is accessible at NOAA Space Environment Center? »

The screenshot shows the SWYP Browsing interface. At the top, a blue banner reads "SWYP Browsing". Below it is an orange banner for "SWYP Source files" with a search box. A green message box states: "Too many entries match your request (12). You can refine your request or look at the first matching entries." Below this is a yellow banner with a "Refine your request" search box. A pink banner says "Only the 10 first matching entries are listed below." A table lists 10 data entries, each with a "GoTo" button and a "Next" button. A blue arrow points from the "Next" button to a box labeled "Next". Another blue arrow points from the "GoTo" button of the 8th entry to a box labeled "Where can I find data from ...".

Source files

ape

SWYP Browsing

SWYP Source files

Too many entries match your request (12). You can refine your request or look at the first matching entries.

Refine your request

Next

Next

Only the 10 first matching entries are listed below.	
U.S. Air Force 45-Day Ap and F10.7cm Forecast Bulletin (ascii file)	
Hourly Averaged ACE Differential Electron and Proton Flux (ascii file)	1
Hourly Predicted ACE Satellite Locations in GSE Coordinates (ascii file)	2
Hourly Averaged ACE Interplanetary Magnetic Field Values (ascii file)	3
Hourly Averaged ACE Integral Flux of High-energy Solar Protons (ascii file)	4
Hourly Averaged ACE Bulk Parameters of the Solar Wind Plasma (ascii file)	5
Last 30 Days Daily Particle Data (ascii file)	6
1-minute average of GOES-8 Geomagnetic Field (ascii file)	7
5-minute GOES-8 Solar Particle Electron Flux Channels (ascii file)	8
5-minute GOES-8 Energetic Proton Flux Channels (uncorrected, ascii file)	9

© BIRA/IASB, last update: 2000-Nov-06

Where can I find data from ...

# « What data is accessible at NOAA Space Environment Center? »

Next

Browsing - Netscape

English **SWYP Browsing**

SWYP Source files

Too many entries match your request (12).  
You can **refine your request** or look at the first matching entries.

Refine your request

Next

Only the 2 last matching entries are listed below.

1-minute average of GOES-8 Solar Xray Flux (ascii file)	10
5-minute average of GOES-8 Solar Xray Flux (ascii file)	11

© BIRA/IASB, last update: 2000-Nov-06

1-min averages

5-min averages

# « What is the availability of the GOES-8 solar X-ray flux data at NOAA/SEC? »

# « What is the availability of the GOES-8 solar X-ray flux data at NOAA/SEC? »

SWYP Browsing - Netscape

SWYP Browsing

1-min averages

SWYP Source files

Entry: GSXR\_1M\_TXT

<b>Description</b>	1-minute average of GOES-8 Solar Xray Flux (ascii file)
<b>Provider</b>	Space Environment Center anonymous FTP system (SEC)
<b>Generic URL</b>	ftp://ftp.sel.noaa.gov/pub/lists/xray/ <del>xxxxxx</del> GSxr_1m.txt
<b>Accessibility period</b>	from 16 days ago to yesterday
<b>Time resolution</b>	60 seconds (or longer)

SWYP Browsing - Netscape

SWYP Browsing

5-min averages

SWYP Source files

Entry: GSXR\_5M\_TXT

<b>Description</b>	5-minute average of GOES-8 Solar Xray Flux (ascii file)
<b>Provider</b>	Space Environment Center anonymous FTP system (SEC)
<b>Generic URL</b>	ftp://ftp.sel.noaa.gov/pub/lists/xray/ <del>xxxxxx</del> GSxr_5m.txt
<b>Accessibility period</b>	from 46 days ago to yesterday
<b>Time resolution</b>	300 seconds (or longer)
<b>Number of columns</b>	8
<b>More ...</b>	Search the web

SWYP Channel catalogue   SE Parameters or indices   Retrieved data files

# « Which space or ground missions are monitoring the geomagnetic field? »

The image displays two screenshots of the SWYP Browsing interface in Netscape. The top screenshot shows the entry for 'B MAG' with a table of properties. The bottom screenshot shows search results for 'Space or ground missions'.

**Top Screenshot: Entry: B MAG**

<b>Description</b>	DC Magnetic field
<b>Unit</b>	Gauss
<b>Valid range</b>	$1 \times 10^{-5} - 0.4$ [Gauss]
<b>Type</b>	Vector
<b>More...</b>	No additional information available

**Bottom Screenshot: Search Results for 'Space or ground missions'**

4 entries match your request

Cluster-II Samba (FM7 or SC3)	SE Models or sensors
Advanced Composition Explorer	SE Models or sensors
NASA/NOAA Geostationary Operational Environmental Satellite - 8	SE Models or sensors
International Real-time Magnetic observatory Network	SE Models or sensors

# « What kind of magnetic data are recorded at the INTERMAGNET Abisko observatory? »

SWYP Browsing - Netscape

Michel Krugavatski SWYP Browsing

SE Models or sensors

Entry: IMO-ABK

<b>Description</b>	INTERMAGNET Abisko Geomagnetic Observatory (Sweden) Fluxgate magnetometer FGE (Danish) with XYZ orientation. Location: 21.64 deg of co-latitude, 18.82 deg of longitude and 380 meters of elevation.
<b>Mission</b>	<a href="#">International Real-time Magnetic observatory Network</a>
<b>Number of channels</b>	4
<b>Time resolution</b>	60 seconds (or longer)
<b>Principal Investigator</b>	B. Olafsdottir (birna@sgu.se)
<b>Institute or centre</b>	Geological Survey of Sweden
<b>Web site</b>	<a href="http://www.sgu.se/index_e.html">www.sgu.se/index_e.html</a>
<b>Address</b>	Box 670 S-751 28 Uppsala SWEDEN
<b>General reference</b>	—
<b>More...</b>	Look at the <a href="http://www.intermagnet.org">www.intermagnet.org</a> web site. You may also check at <a href="#">NSSDC</a>

SWYP Channel catalogue SE Parameters or indices SWYP Source files

Your workspace contains already 3 entries

List of channels

# « What kind of magnetic data are recorded at the INTERMAGNET Abisko observatory? »

**SWYP Channel catalogue**

4 entries match your request

Bmag_n_geo <Imo-abk@INTERMAGNET> (Edi_abk_txt#1)	Mission description
Bmag_p_geo <Imo-abk@INTERMAGNET> (Edi_abk_txt#2)	Mission description
Bmag_nadir <Imo-abk@INTERMAGNET> (Edi_abk_txt#3)	Mission description
Bmag_norm <Imo-abk@INTERMAGNET> (Edi_abk_txt#4)	Mission description

---

**SWYP Browsing**

Entry 86 := Bmag\_n\_geo <Imo-abk@INTERMAGNET> (Edi\_abk\_txt#1)

<b>Sensor or detector</b>	INTERMAGNET Abisko Geomagnetic Observatory (Sweden)
<b>Mission</b>	International Real-time Magnetic observatory Network
<b>Measurement quantity</b>	DC Magnetic field [1×10 <sup>-5</sup> × Gauss] - Anti-theta-component in geocentric spherical coordinate system (Northwards)
<b>Source file</b>	1-minute average Abisko magnetograms from Edinburgh GIN [Edinburgh Geomagnetic Information Node]

Similar channels for the same sensor      Similar channels for other sensors

# « Are there unidirectional proton flux measurements for energies between 1 and 4 MeV? »

SWYP Browsing - Netscape

Michel Kruglantz **SWYP Browsing**

SE Parameters or indices

Entry: PUD\_FLUX

<b>Description</b>	Unidirectional differential proton flux
<b>Unit</b>	$\text{cm}^{-2} \text{sr}^{-1} \text{keV}^{-1} \text{s}^{-1}$
<b>Valid range</b>	$0.001 - 1 \times 10^6 [\text{cm}^{-2} \text{sr}^{-1} \text{keV}^{-1} \text{s}^{-1}]$
<b>Type</b>	Scalar
<b>Depends on</b>	Proton energy
<b>More...</b>	No additional information available

SWYP Channel catalogue SE Models or sensors

SE Space or ground missions SWYP Source files

Search for SWYP channels in a restricted range of... Proton energy  -  [MeV]

Channel selection

Your workspace contains already 3 entries

© BIRA/LASE, last update: 2000-Nov-06

# « Are there unidirectional proton flux measurements for energies between 1 and 4 MeV? »

**Channel selection**

SWYP Browsing

SWYP Channel catalogue

8 entries match your request

Pud\_flux\_none <Ep8@GOES-8> (G8pchan\_5m\_txt#7) Mission description

Pud\_flux\_none <Ep8@GOES-8> (G8\_k0\_ep8\_cdf#16) Mission description

SWYP Browsing - Netscape

SWYP Channel catalogue

Entry 25 := Pud\_flux\_none <Ep8@GOES-8> (G8pchan\_5m\_txt#7)

<b>Sensor or detector</b>	GOES-8 Energetic Particle Monitor
<b>Mission</b>	NASA/NOAA Geostationary Operational Environmental Satellite - 8
<b>Measured quantity</b>	Unidirectional differential proton flux [0.001 x cm <sup>-2</sup> sr <sup>-1</sup> keV <sup>-1</sup> s <sup>-1</sup> ] - (Scalar data)
<b>Proton energy</b>	0.7 - 4 [MeV]
<b>Source file</b>	5-minute GOES-8 Energetic Proton Flux Channels (uncorrected, ascii file) [Space Environment Center anonymous FTP system]

Similar channels for the same sensor

Similar channels for other sensors

Similar channels for other missions

Other channels from the same source file

« I have the 175-315 keV electron flux data from ACE/EPAM. Are there similar measurements from other spacecraft? »

SWYP Browsing - Netscape

Michel Krughardt SWYP Browsing

SWYP Channel catalogue

Entry 74 := Eud\_flux\_none <Epam@ACE> (Ace\_epam\_1h\_txt#9)

Sensor or detector	<a href="#">ACE Electron, Proton, and Alpha-particle Monitor</a>
Mission	<a href="#">Advanced Composition Explorer</a>
Measured quantity	<a href="#">Unidirectional differential electron flux</a> [0.001 x cm <sup>-2</sup> sr <sup>-1</sup> keV <sup>-1</sup> s <sup>-1</sup> ] - (Scalar data)
Electron energy	175 - 315 [keV]
Source file	<a href="#">Hourly Averaged ACE Differential Electron and Proton Flux (ascii file)</a> [Space Environment Center anonymous FTP system]

Similar channels for the same sensor    Similar channels for other sensors

Similar channels for other missions    Other channels from the same source file

Your workspace contains already 3 entries

© BIRA/LASB, last update: 2000-Nov-06

Other missions

« I have the 175-315 keV electron flux data from ACE/EPAM. Are there similar measurements from other spacecraft? »

Other missions → SWYP Browsing

SWYP Channel catalogue

9 entries match your request

Eud_flux_none <Sopa@1994-084> (Sopa1994084_txt#5)	Mission description
Eud_flux_none <Sopa@1994-084> (Sopa1994084_txt#6)	Mission description
Eud_flux_none <Sopa@1994-084> (Sopa1994084_txt#7)	Mission description
Eud_flux_none <Sopa@1994-084> (Sopa1994084_txt#8)	Mission description
Eud_flux_none <Sopa@1994-084> (Sopa1994084_txt#9)	Mission description
Eud_flux_none <Sopa@1994-084> (Sopa1994084_txt#10)	Mission description
Eud_flux_none <Sopa@1994-084> (Sopa1994084_txt#11)	Mission description
Eud_flux_none <Sopa@1994-084> (Sopa1994084_txt#12)	Mission description
Eud_flux_none <Sopa@1994-084> (Sopa1994084_txt#13)	Mission description

Channels in energy range →

Your workspace contains already 3 entries

© BIRALISE, last update: 2000-Nov-06

« I have the 175-315 keV electron flux data from ACE/EPAM. Are there similar measurements from other spacecraft? »

The screenshot shows the SWYP Browsing interface in Netscape. It displays two channel entries, Entry 97 and Entry 98, with their respective metadata tables. Red circles highlight the 'Electron energy' fields for both entries: '150 - 225 [keV]' for Entry 97 and '225 - 315 [keV]' for Entry 98. A blue callout box with an arrow points to the 'Electron energy' field of Entry 97, containing the text 'Channels in energy range'.

Field	Value
Sensor or detector	LANL 1994-084 Synchronous Orbit Particle Analyzer
Mission	Los Alamos (LANL) geosynchronous satellite 1994
Measured quantity	Unidirectional differential electron flux $\text{cm}^{-2} \text{sr}^{-1} \text{keV}^{-1} \text{s}^{-1}$ (Scalar data)
Electron energy	150 - 225 [keV]
Source file	1-minute 1994-084 LANL Synchronous Orbit Particle Analyzer energetic particles data record [LANL Geosynchronous energetic particles data record]

Field	Value
Sensor or detector	LANL 1994-084 Synchronous Orbit Particle Analyzer
Mission	Los Alamos (LANL) geosynchronous satellite 1994
Measured quantity	Unidirectional differential electron flux $\text{cm}^{-2} \text{sr}^{-1} \text{keV}^{-1} \text{s}^{-1}$ (Scalar data)
Electron energy	225 - 315 [keV]
Source file	1-minute 1994-084 LANL Synchronous Orbit Particle Analyzer energetic particles data record [LANL Geosynchronous energetic particles data record]

# **Level 2**

# **Data retrieval and model**

# **runs**

« I want to retrieve 1-hour data from several ACE instruments. »

The screenshot shows a Netscape browser window titled "Your workspace - Netscape". The interface is divided into several sections:

- Header:** A blue bar with a user profile icon for "Michel Crughan" and the text "Your workspace". To the right are icons for search, globe, help, and a folder.
- Status Bar:** A green bar with a lightbulb icon and the text "The workspace contains 8 entries".
- Channel Catalogue:** An orange bar with a question mark icon, the text "SWYP Channel catalogue", and "8 / 8".
- Channel List:** A list of eight channels, each with a question mark icon, a name, and a trash can icon with a red 'X'. The channels are:
  - Swid\_none <Swepam@ACE> (Ace\_swepam\_1h\_t#8)
  - Swt\_none <Swepam@ACE> (Ace\_swepam\_1h\_t#10)
  - Bmag\_norm <Acemag@ACE> (Ace\_mag\_1h\_txt#11)
  - Sat\_loc\_gsmlat <Ace\_sat@ACE> (Ace\_mag\_1h\_txt#12)
  - Sat\_loc\_gsmlong <Ace\_sat@ACE> (Ace\_mag\_1h\_txt#13)
  - Pud\_flux\_none <Eepam@ACE> (Ace\_epam\_1h\_txt#13)
  - Pud\_flux\_none <Eepam@ACE> (Ace\_epam\_1h\_txt#14)
  - Pui\_flux\_none <Sis@ACE> (Ace\_sis\_1h\_txt#8)
- Data Retrieval Form:** A green bar with the text "Retrieve data for a period...". It includes a "starting at" dropdown set to "noon", an "on" dropdown set to "4", a month dropdown set to "Apr", a day dropdown set to "20", a year dropdown set to "0", and a "during" dropdown set to "5 days". There is also a small icon of a notepad and pencil.

A blue callout box with an arrow points to the bottom right of the interface, containing the text "Data retrieval tool".

« I want to retrieve 1-hour data from several ACE instruments. »

**Data retrieval tool**

Request submission...

id := 207  
user := michel\_0207  
code := 10408

Requested epoch	from 04 Apr 2000 12:00:00 until 09 Apr 2000 11:59:59	
Requested channel(s)	Pud_flux_none (Ace_epam_1h_txt#13)	ACE Space mission
	Pud_flux_none (Ace_epam_1h_txt#14)	(same file)
	Bmag_norm (Ace_mag_1h_txt#11)	(same mission)
	Sat_loc_gsmlat (Ace_mag_1h_txt#12)	(same file)
	Sat_loc_gsmlong (Ace_mag_1h_txt#13)	(same file)
	Pui_flux_none (Ace_sis_1h_txt#8)	(same mission)
	Swid_none (Ace_swepam_1h_t#8)	(same mission)
	Swt_none (Ace_swepam_1h_t#10)	(same file)

Your request has been submitted and will be executed within the next 285 minutes.  
The system will send you an e-mail on completion.

**System e-mail**

Data files of this request    
 Data files of pending requests  
 Check the status of your requests    
 Empty your workspace ()

© BIRA/IASE, last update: 2001-Jul-24

« I want to retrieve 1-hour data from several ACE instruments. »

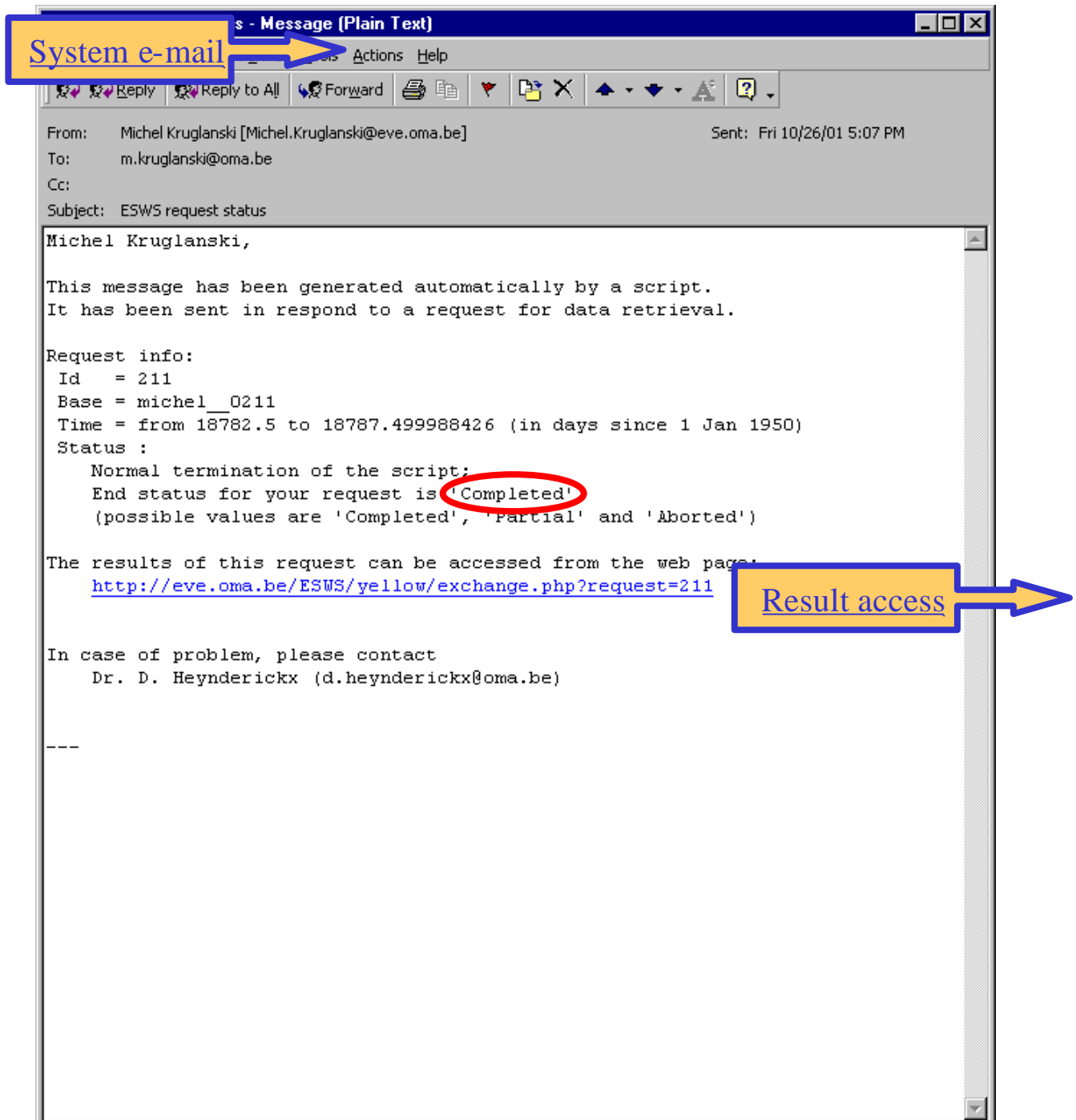

# « I want to retrieve 1-hour data from several ACE instruments. »

**Data retrieval centre - Netscape**

**Data retrieval centre**

Entry: 211

<b>Request status</b>	Completed
<b>Time period</b>	from 4 Jun 2001 (12:00:00) until 9 Jun 2001 (11:59:59)
<b>Result</b>	Ascii comma separated file: ... 0211.csv
<b>Description</b>	<p>Block 1</p> <ul style="list-style-type: none"><li>7 associated retrieved file(s) <a href="#">[see details]</a></li><li>Unidirectional differential proton flux, (Scalar data), 0.761 - 1.22 [MeV] <a href="#">[channel 78]</a></li><li>Unidirectional differential proton flux, (Scalar data), 1.06 - 1.91 [MeV] <a href="#">[channel 79]</a></li></ul> <p>Block 2</p> <ul style="list-style-type: none"><li>7 associated retrieved file(s) <a href="#">[see details]</a></li><li>DC Magnetic field, Strength of the vector <a href="#">[channel 67]</a></li><li>Spacecraft location (support data), GSM Latitude (in degrees) <a href="#">[channel 68]</a></li><li>Spacecraft location (support data), GSM Longitude (in degrees) <a href="#">[channel 69]</a></li></ul> <p>Block 3</p> <ul style="list-style-type: none"><li>7 associated retrieved file(s) <a href="#">[see details]</a></li><li>Unidirectional integral proton flux, (Scalar data), 10 - 100 [MeV] <a href="#">[channel 80]</a></li></ul> <p>Block 4</p> <ul style="list-style-type: none"><li>7 associated retrieved file(s) <a href="#">[see details]</a></li><li>Plasma temperature, (Scalar data) <a href="#">[channel 63]</a></li></ul>

Preview request results for:

Your workspace contains already 7 entries

© BIRA/IASB, last update: 2001-Jul-17

# « I want to retrieve 1-hour data from several ACE instruments. »

Result preview

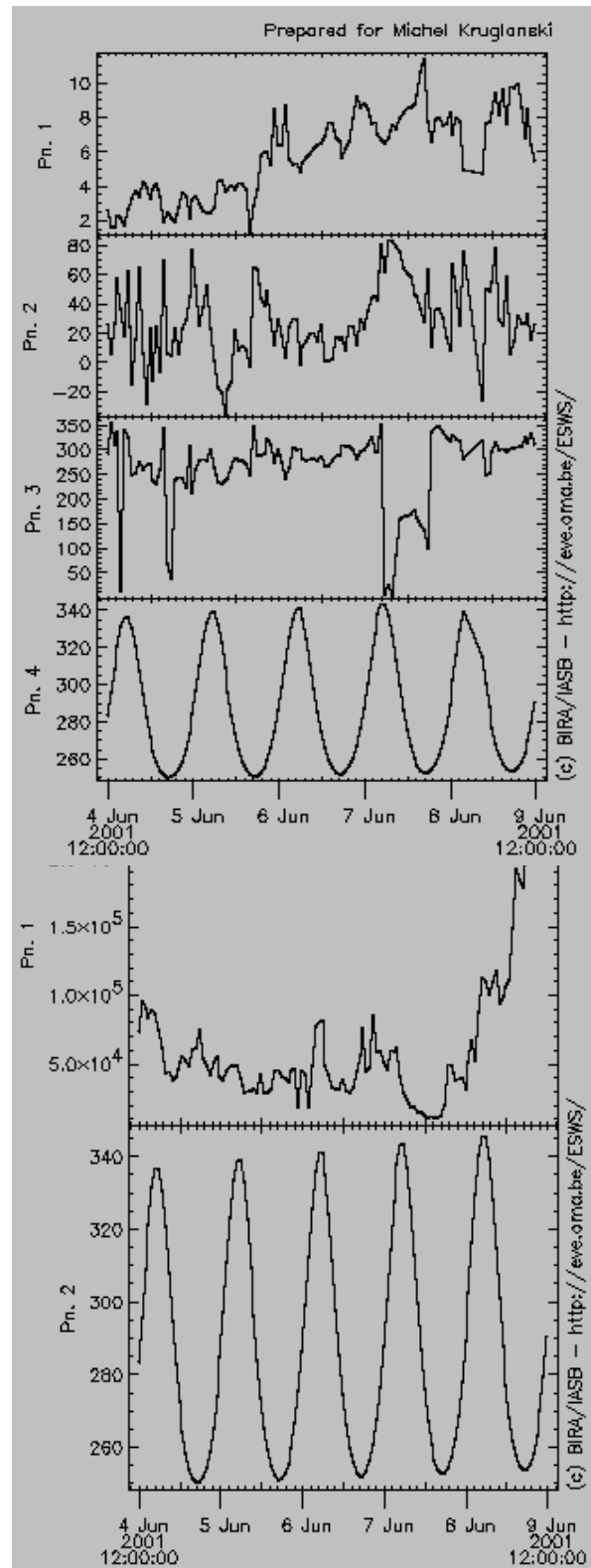
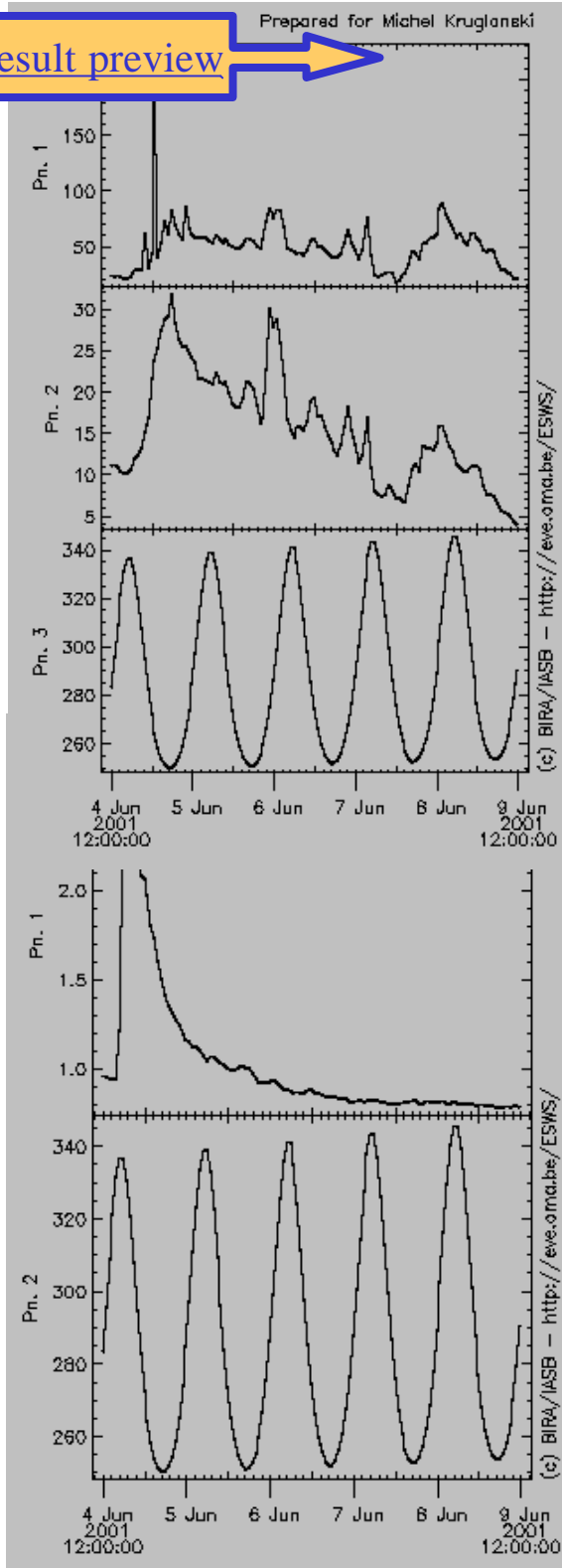

# « I want to retrieve proton flux data from ACE and GOES-8. »

Your workspace - Netscape

Michel Krugler Your workspace

The workspace contains 8 entries

SWYP Channel catalogue 8 / 8

Pud_flux_none <Ep8@GOES-8> (G8pchan_5m_txt#7)	
Pud_flux_none <Ep8@GOES-8> (G8pchan_5m_txt#8)	
Pui_flux_none <Ep8@GOES-8> (G8part_5m_txt#9)	
Pui_flux_none <Ep8@GOES-8> (G8part_5m_txt#10)	
Pud_flux_none <Epam@ACE> (Ace_epam_1h_txt#13)	
Pud_flux_none <Epam@ACE> (Ace_epam_1h_txt#14)	
Pui_flux_none <Sis@ACE> (Ace_sis_1h_txt#8)	
Pui_flux_none <Sis@ACE> (Ace_sis_1h_txt#9)	

Retrieve data for a period... starting at midnight on 20 Sep 20 0 1 during 3 days

Data retrieval tool

# « I want to retrieve proton flux data from ACE and GOES-8. »

**Data retrieval tool**

Request submission...  
 ID : 208  
 NAME : michel\_0208  
 CODE : 14408

Requested epoch	from 20 Sep 2001 00:00:00 until 22 Sep 2001 23:59:59	
Requested channel(s)	Pud_flux_none (G8pchan_5m_txt#7)	<b>GOES-8 Space mission</b>
	Pud_flux_none (G8pchan_5m_txt#8)	(same file)
	Pui_flux_none (G8part_5m_txt#9)	(same mission)
	Pui_flux_none (G8part_5m_txt#10)	(same file)
	Pud_flux_none (Ace_epam_1h_txt#13)	<b>ACE Space mission</b>
	Pud_flux_none (Ace_epam_1h_txt#14)	(same file)
	Pui_flux_none (Ace_sis_1h_txt#8)	(same mission)
	Pui_flux_none (Ace_sis_1h_txt#9)	(same file)

Your request has been submitted and will be executed within the next 205 minutes.  
 The system will send you an e-mail on completion.

Data files of this request    
 Data files of pending requests  
 Check the status of your requests    
 Empty your workspace ()

© BIRA/IASE, last update: 2001-Jul-24

**System e-mail, result access**

# « I want to retrieve proton flux data from ACE and GOES-8. »

**Data retrieval centre - Netscape**

Michel Kraghede **Data retrieval centre**

Entry: 208

<b>Request status</b>	Completed
<b>Time period</b>	from 20 Sep 2001 until 22 Sep 2001 (23:59:59)
<b>Result</b>	Ascii comma separated file: ... 0208.csv
<b>Description</b>	<p>Block 1</p> <ul style="list-style-type: none"><li>6 associated retrieved file(s) <a href="#">[see details]</a></li><li>Unidirectional differential proton flux, (Scalar data), 0.7 - 4 [MeV] <a href="#">[channel 25]</a></li><li>Unidirectional differential proton flux, (Scalar data), 4 - 9 [MeV] <a href="#">[channel 26]</a></li></ul> <p>Block 2</p> <ul style="list-style-type: none"><li>6 associated retrieved file(s) <a href="#">[see details]</a></li><li>Unidirectional integral proton flux, (Scalar data), 10 - 700 [MeV] <a href="#">[channel 38]</a></li><li>Unidirectional integral proton flux, (Scalar data), 30 - 700 [MeV] <a href="#">[channel 39]</a></li></ul> <p>Block 3</p> <ul style="list-style-type: none"><li>4 associated retrieved file(s) <a href="#">[see details]</a></li><li>Unidirectional differential proton flux, (Scalar data), 0.761 - 1.22 [MeV] <a href="#">[channel 78]</a></li><li>Unidirectional differential proton flux, (Scalar data), 1.06 - 1.91 [MeV] <a href="#">[channel 79]</a></li></ul> <p>Block 4</p> <ul style="list-style-type: none"><li>4 associated retrieved file(s) <a href="#">[see details]</a></li><li>Unidirectional integral proton flux, (Scalar data), 10 - 100 [MeV] <a href="#">[channel 80]</a></li><li>Unidirectional integral proton flux, (Scalar data), 30 - 100 [MeV] <a href="#">[channel 81]</a></li></ul>

Preview request results for:  [Result preview](#)

Your workspace contains already 7 entries

© BIRA/IASE, last update: 2001-Jul-17

# « I want to retrieve proton flux data from ACE and GOES-8. »

Result preview

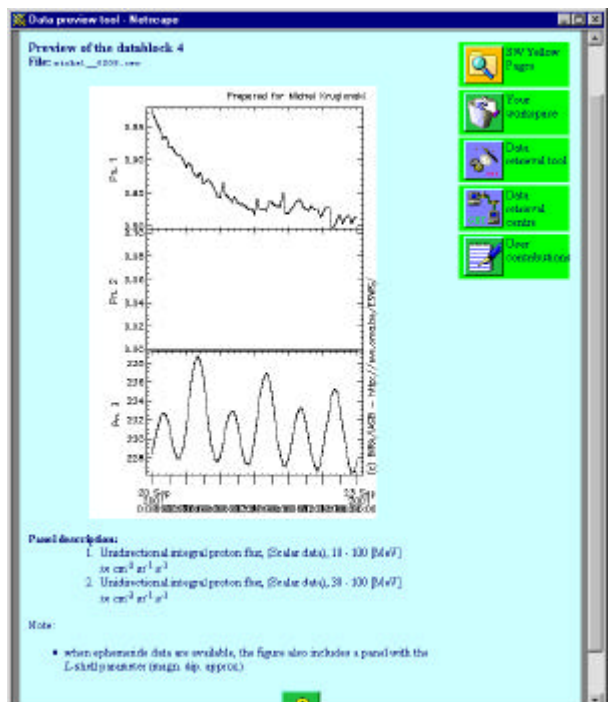
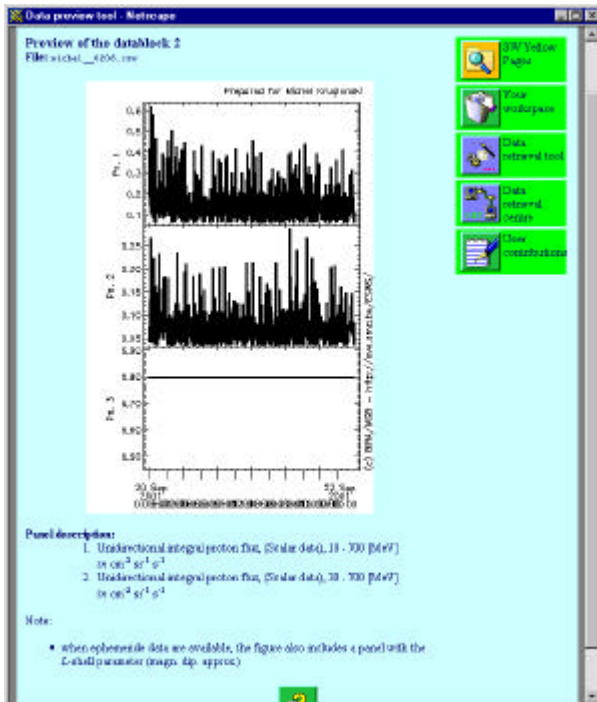
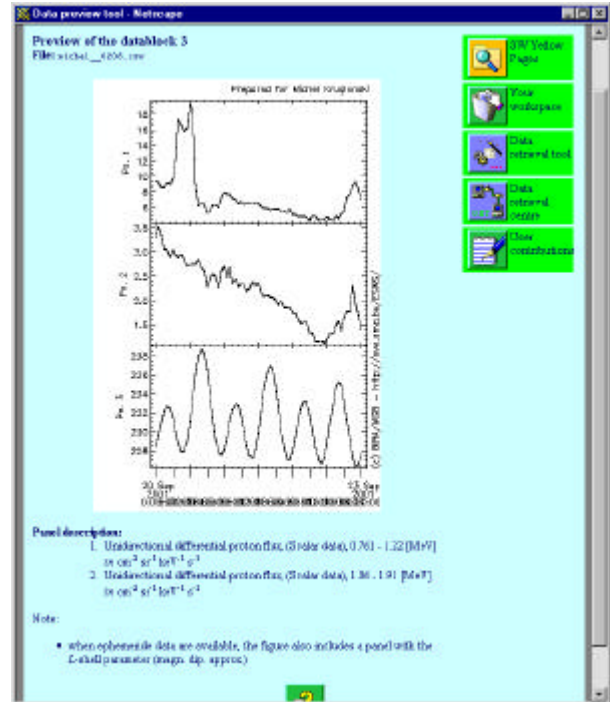
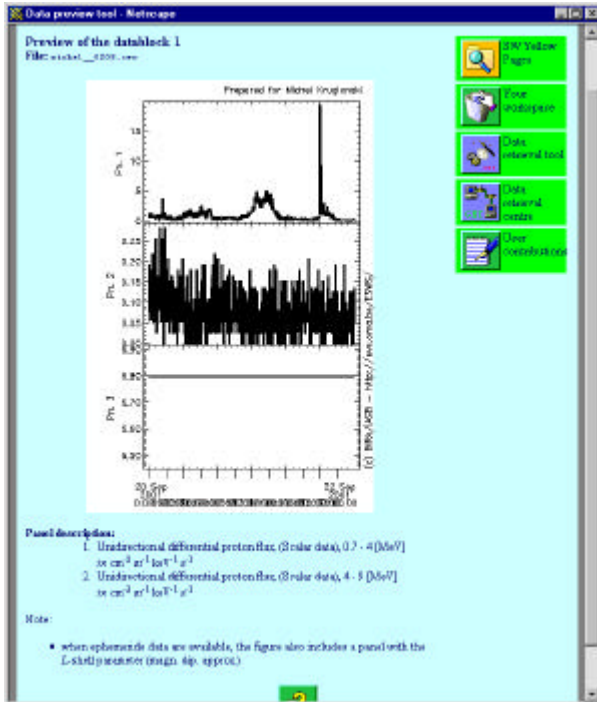

« I want to retrieve magnetic field data from the INTERMAGNET stations Hurbanovo and Lovo. »

The screenshot shows two Netscape browser windows. The top window, titled "Your workspace - Netscape", displays a workspace with four entries. The bottom window, titled "Data retrieval tool - Netscape", shows a request submission form. A blue arrow points from the workspace to the tool.

**Your workspace - Netscape**

Michel English  
Your workspace

The workspace contains 4 entries

SWYP Channel catalogue	4 / 4
Bmag_n_geo <Imo-lov@INTERMAGNET> (Edi_lov_txt#1)	
Bmag_nadir <Imo-lov@INTERMAGNET> (Edi_lov_txt#3)	
Bmag_n_geo <Imo-hrb@INTERMAGNET> (Edi_hrb_txt#1)	

**Data retrieval tool - Netscape**

Michel English  
Data retrieval tool

Request submission...

no := 209  
max := michel\_0209  
com := 2204

<b>Requested epoch</b>	from 01 Jan 2000 00:00:00 until 01 Jan 2000 23:59:59	
<b>Requested channel(s)</b>	Bmag_n_geo (Edi_hrb_txt#1)	[ INTERMAGNET ]
	Bmag_nadir (Edi_hrb_txt#3)	(same file)
	Bmag_n_geo (Edi_lov_txt#1)	(same mission)
	Bmag_nadir (Edi_lov_txt#3)	(same file)

Your request has been submitted and will be executed within the next 15 minutes.  
The system will send you an e-mail on completion.

Data files of this request     Data files of pending requests  
 Check the status of your requests     Empty your workspace ()

« I want to retrieve magnetic field data from the INTERMAGNET stations Hurbanovo and Lovo. »

Data retrieval centre - Netscape

Michel Krugavats Data retrieval centre

Entry: 209

<b>Request status</b>	Completed
<b>Time period</b>	1 Jan 2000: from 00:00:00 until 23:59:59
<b>Result</b>	Ascii comma separated file: ... 0209.csv
<b>Description</b>	<p>Block 1</p> <ul style="list-style-type: none"><li>1 associated retrieved file(s) [see details]</li><li>DC Magnetic field, Anti-theta-component in geocentric spherical coordinate system (Northwards) [channel190]</li><li>DC Magnetic field, Anti-radial component in geocentric coordinate system [channel192]</li></ul> <p>Block 2</p> <ul style="list-style-type: none"><li>1 associated retrieved file(s) [see details]</li><li>DC Magnetic field, Anti-theta-component in geocentric spherical coordinate system (Northwards) [channel182]</li><li>DC Magnetic field, Anti-radial component in geocentric coordinate system [channel184]</li></ul>

Preview request results for block 1

Result preview

Your workspace contains one entry

© BIRA/IASE, last update: 2001-Jul-17

« I want to retrieve magnetic field data from the INTERMAGNET stations Hurbanovo and Lovo. »

Data file

	A	B	C	D	E	F	G	H
1	*	13	6	3	0	3	3	1440
2	SWYP - store_data - Fri Oct 26 15:44:16 2001 - Author: BIRA/IASB (MK)							
3	SWYP - extr_intermagmet - Fri Oct 26 15:44:15 2001 - Author: BIRA/IASB (DH)							
4	Observatory: HRB; latitude: 48.0, east longitude: 18.2							
5	Date: 01/01/2000; data type: Reported							
6	1440 records extracted							
7	TOTAL: 1440 data extracted							
8	MISSION -1 International Real-time Magnetic observatory Network							
9	T_PERIOD -2 1-Jan-2000 00:00:00 2-Jan-2000 00:00:00							
10	DTA_FILES -1 EDI_HRB_20000101.txt							
11	MJD	days	1 Time since 1st January 1950					
12	BMAG_N_GEO_1	Gauss	1 DC Magnetic field, Anti-theta-compon					
13	BMAG_NADIR_3	Gauss	1 DC Magnetic field, Anti-radial compor					
14	18262	2.09131	4.3274899					
15	18262.001	2.09128	4.3274899					
16	18262.001	2.09115	4.3275199					
17	18262.002	2.09092	4.3275299					
18	18262.003	2.09094	4.3275299					
19	18262.003	2.09076	4.3275199					
1453	18262.999	2.0949099	4.3275499					
1454	END OF BLOCK							
1455	*	13	6	3	0	3	3	1440
1456	SWYP - store_data - Fri Oct 26 15:45:17 2001 - Author: BIRA/IASB (MK)							
1457	SWYP - extr_intermagmet - Fri Oct 26 15:45:16 2001 - Author: BIRA/IASB (DH)							
1458	Observatory: LOV; latitude: 59.3, east longitude: 17.2							
1459	Date: 01/01/2000; data type: Reported							
1460	1440 records extracted							
1461	TOTAL: 1440 data extracted							
1462	MISSION -1 International Real-time Magnetic observatory Network							
1463	T_PERIOD -2 1-Jan-2000 00:00:00 2-Jan-2000 00:00:00							
1464	DTA_FILES -1 EDI_LOV_20000101.txt							
1465	MJD	days	1 Time since 1st January 1950					
1466	BMAG_N_GEO_1	Gauss	1 DC Magnetic field, Anti-theta-compon					
1467	BMAG_NADIR_3	Gauss	1 DC Magnetic field, Anti-radial compor					
1468	18262	1.5262901	4.8404198					
1469	18262.001	1.52592	4.8402801					
1470	18262.001	1.52562	4.84021					
1471	18262.002	1.52556	4.8403301					
1472	18262.003	1.52548	4.8404498					

# « I want to retrieve magnetic field data from the INTERMAGNET stations Hurbanovo and Lovo. »

**Result preview** →

Michel Kruglanski
**Data preview tool**

Preview of the datablock 1  
File: michel\_\_0209.csv

Prepared for Michel Kruglanski

(c) BIRA/IASB - <http://eve.oma.be/ESWS/>

**Panel description:**

- DC Magnetic field, Anti-theta-component in geocentric spherical coordinate system (Northwards) in Gauss
- DC Magnetic field, Anti-radial component in geocentric coordinate system in Gauss

Michel Kruglanski
**Data preview tool**

Preview of the datablock 2  
File: michel\_\_0209.csv

Prepared for Michel Kruglanski

(c) BIRA/IASB - <http://eve.oma.be/ESWS/>

**Panel description:**

- DC Magnetic field, Anti-theta-component in geocentric spherical coordinate system (Northwards) in Gauss

# « I want to evaluate the cosmic ray LET spectrum for XMM. »

**Ephemeris Tool**

**XMM-Newton X-ray Multimirror Mission**

<b>NORAD TLE</b>	2 25919 20100A 03291.00000001 .00000000 0000-0 0000-0 0 3304 2 25919 32.5281 204.8155 00000000 91.5404 332.4923 0.5000(433) 3341
<b>TLE Epoch</b>	19 Oct 2001 16:00:00
<b>Inclination</b>	33.54 [deg]
<b>Eccentricity <math>e_0</math></b>	0.80689
<b>Mean motion <math>n_0</math></b>	0.50 [rev/day] = 3.14753 [rad/day]
<b>Evaluation on 19 Oct 2001 16:00:00</b>	
<b>Age of extrapolation</b>	-0.00 [day]
<b>Perigee, apogee</b>	6554.4 – 114626.6 [km]
<b>Right ascension of the ascending node</b>	184.88 [deg]
<b>Argument of perigee</b>	97.55 [deg]
<b>True anomaly</b>	279.89 [deg]
<b>GEI Location</b>	$x: -19072.5, y: -6772.2, z: 3398.3$ [km]
<b>Velocity</b>	20648.3 [km/h] = 5.736 [km/s]

SPENVIS Orbit Generator

© BIR/IASB, last update: 2000-Nov-14

Run SPENVIS orbit generator and models

# « I want to evaluate the cosmic ray LET spectrum for XMM. »

Radiation analysis: Energy and LET spectra model parameters - Netscape

SPENVIS Project: [ZZZ](#)

**Up** **Index** **Tables** **Plots** **Help**

**Radiation analysis**  
Energy and LET spectra: Model parameters

### Model parameters

Shielding thickness:  ()

Composition: Select the lightest element  and the heaviest element  to be included in the LET spectra.

Interplanetary weather condition:

Magnetic weather conditions:

### Trapped protons

No trapped proton spectra were found for the current project. If trapped protons are to be included in the calculation, [run the trapped radiation models](#) and return to this page.

**Caution!** This application is very time consuming and may take several minutes to complete, depending on the orbit length and the number of elements in the spectrum. If your browser experiences a time-out, run this application in batch mode (batch mode can be set via the project link at the top of the page).

Model developed by



[Run SPENVIS model](#)

Document: Done

# « I want to evaluate the cosmic ray LET spectrum for XMM. »

Run SPENVIS  
model

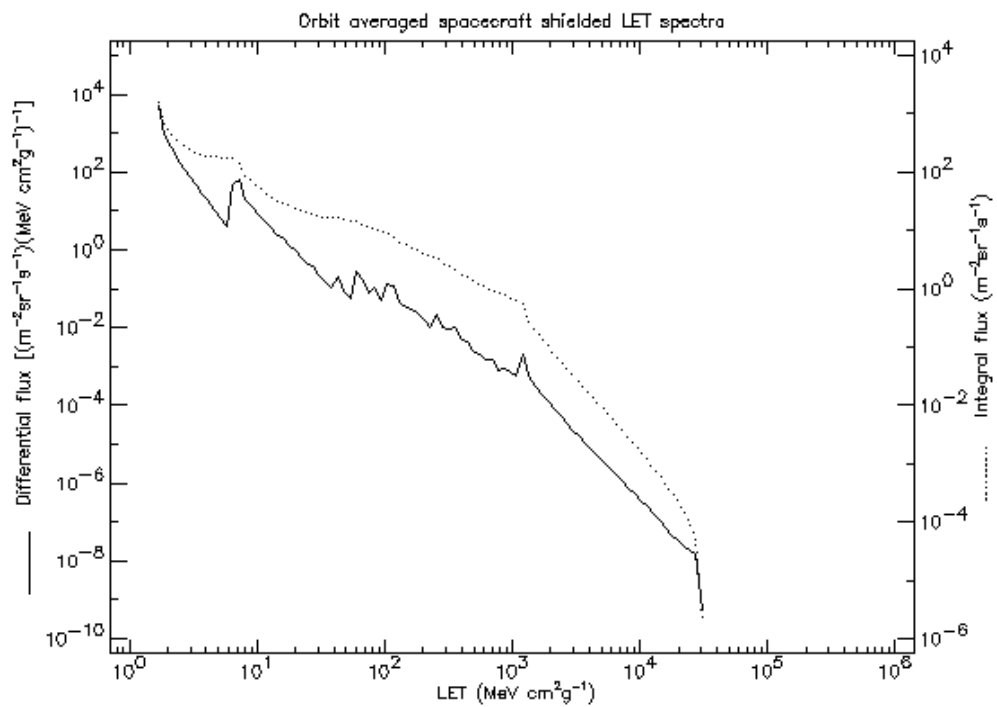
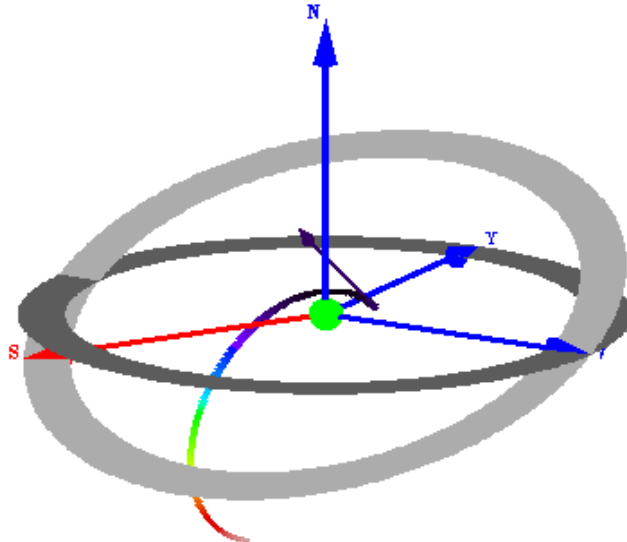

« I want to compare the AP-8 MAX and CRRESPRO models over the Polar orbit. »

The screenshot shows a Netscape browser window titled "Your workspace - Netscape". The main content area is titled "Your workspace" and contains a list of 9 entries. The first entry is a light blue bar stating "The workspace contains 9 entries". The second entry is an orange bar labeled "SWYP Channel catalogue" with a "8 / 9" indicator. The following seven entries are yellow bars, each representing a data file: "Poi\_flux\_none <Ap8-max@RADBELT> (Ap8max\_csv#5)", "Poi\_flux\_none <Ap8-max@RADBELT> (Ap8max\_csv#7)", "Poi\_flux\_none <Ap8-max@RADBELT> (Ap8max\_csv#9)", "Poi\_flux\_none <Ap8-max@RADBELT> (Ap8max\_csv#10)", "Poi\_flux\_none <Acp-qui@RADBELT> (Acpqui\_csv#5)", "Poi\_flux\_none <Acp-qui@RADBELT> (Acpqui\_csv#7)", and "Poi\_flux\_none <Acp-qui@RADBELT> (Acpqui\_csv#9)". Each of these entries has a trash can icon with a red 'X' to its right. Below the list is a green bar with a "Retrieve data for a period..." section, including dropdown menus for "starting at" (set to "midnight"), "on" (set to "1", "Dec", "20", "0", "0"), and "during" (set to "10 days"). At the bottom, there are two more entries: an orange bar labeled "Other catalogue" and a yellow bar labeled "Polar spacecraft", which is circled in red. A blue callout box with an arrow points to the "Polar spacecraft" entry, containing the text: "Retrieval tool, system e-mail, result access".

# « I want to compare the AP-8 MAX and CRRESPRO models over the Polar orbit. »

[Retrieval tool,](#)  
[system e-mail,](#)  
[result access](#)  
+  
[user application](#)

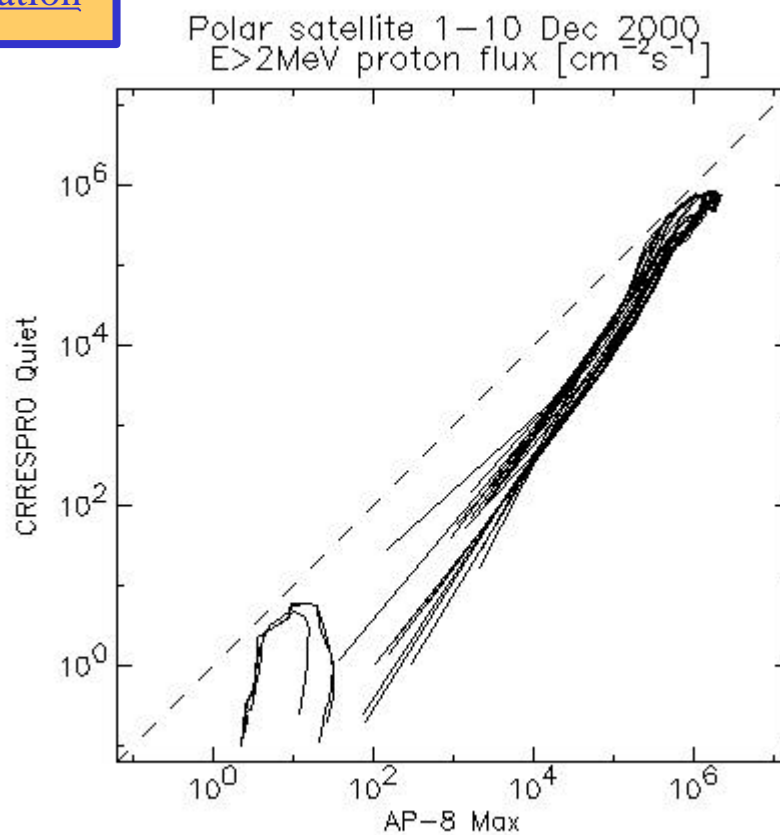

# **Level 3**

# **Parameter retrieval**

« I want to retrieve magnetic field data at geostationary orbit »

The screenshot shows two browser windows. The top window, titled "Your workspace - Netscape", displays a workspace with one entry: "DC Magnetic field". A search bar below the workspace contains the text "Geostationary Orbit". The bottom window, titled "Interface for Level 3 - Netscape", shows the "DC Magnetic field [details]" page. It features a "Requested data" section with a "Build your query..." form. The form includes a "Starting:" section with a time dropdown set to "midnight" and a date selector set to "1 Oct 20 0 0". The "During:" section is set to "5 days". Below this is a "Confirm values for geostationary orbit:" section with several input fields:
 

Altitude from	35000.0	to	51000.0	km,
Latitude from	-2.0	to	2.0	deg;
Magnetic latitude from	-25.0	to	25.0	deg;
Distance to the Sun from	1.0000	to	1.0000	AU;
Dipole L value from	6.5	to	1.0	Re;
Y GSE component from	-45000.0	to	45000.0	km

 At the bottom of the interface, it says "Your workspace contains one entry". A copyright notice at the bottom right reads "© BIRA/IASB, last update: 2001-Jul-31".

Process user query →

# « I want to retrieve magnetic field data at geostationary orbit »

**Process user query**

Interface for Level 3

<b>Requested data</b>	DC Magnetic field [ <a href="#">details</a> ]
<b>Requested period</b>	from 1 Oct 2000 until 5 Oct 2000 (23:59:59)
<b>Requested space region</b>	Altitude from 35000.0 to 37000.0 km; Latitude from -2.0 to 2.0 deg; Magnetic latitude from -15.0 to 15.0 deg; Distance to the Sun between 0.9997 and 1.0003 AU; Dipole L value from 6.5 to 7.0 Re; YGSE component between -42000.0 and 42000.0 km.

9 Channels are matching your query.  
( **warning = LOCATION FILTER NOT FULLY IMPLEMENTED** )

Channel list	
<input type="checkbox"/> Bmag_x_gse <Tfm-g8@GOES-8> (G8_k0_mag_cdf#7) [ <a href="#">details</a> ]	
<input type="checkbox"/> Bmag_y_gse <Tfm-g8@GOES-8> (G8_k0_mag_cdf#8) [ <a href="#">details</a> ]	
<input type="checkbox"/> Bmag_z_gse <Tfm-g8@GOES-8> (G8_k0_mag_cdf#9) [ <a href="#">details</a> ]	
<input type="checkbox"/> Bmag_x_gse <Tfm-g8@GOES-8> (G8_k0_mag_cdf#10) [ <a href="#">details</a> ]	
<input type="checkbox"/> Bmag_y_gsm <Tfm-g8@GOES-8> (G8_k0_mag_cdf#11) [ <a href="#">details</a> ]	
<input type="checkbox"/> Bmag_z_gsm <Tfm-g8@GOES-8> (G8_k0_mag_cdf#12) [ <a href="#">details</a> ]	
<input type="checkbox"/> Bmag_nadir <Tfm-g8@GOES-8> (G8_k0_mag_cdf#13) [ <a href="#">details</a> ]	
<input type="checkbox"/> Bmag_p_geo <Tfm-g8@GOES-8> (G8_k0_mag_cdf#14) [ <a href="#">details</a> ]	
<input type="checkbox"/> Bmag_z_geo <Tfm-g8@GOES-8> (G8_k0_mag_cdf#15) [ <a href="#">details</a> ]	

Select desired channels...

**Data selection and retrieval tool**

Your workspace contains one entry

© BIRA/IASB, last update: 2001-Jul-31

« I want to retrieve magnetic field data for a location near Lagrange point L1 »

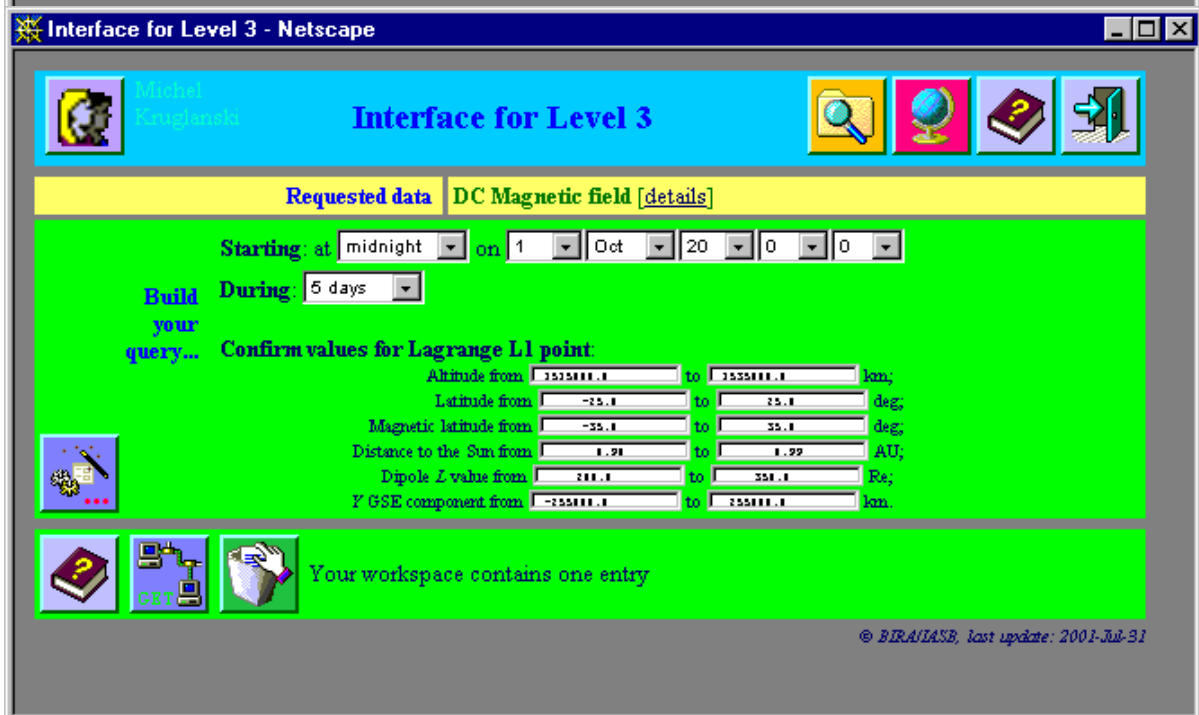
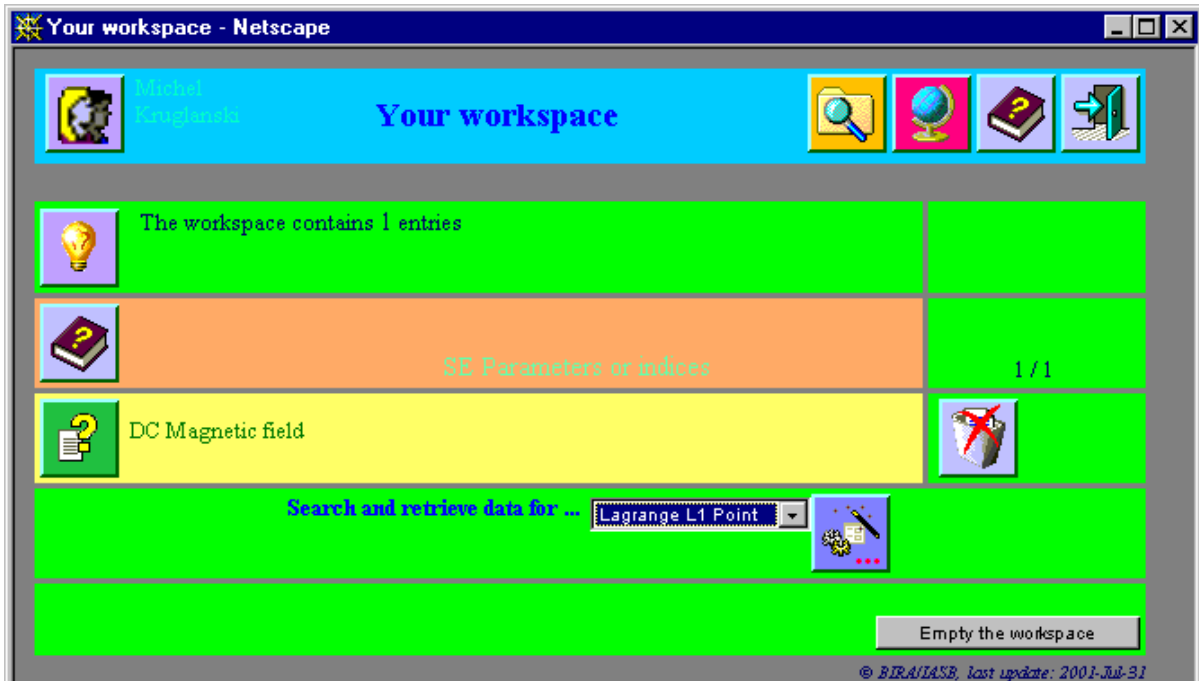

Process user query →

# « I want to retrieve magnetic field data for a location near Lagrange point L1 »

**Process user query**

Interface for Level 3

<b>Requested data</b>	DC Magnetic field [details]
<b>Requested period</b>	from 1 Oct 2000 until 5 Oct 2000 (23:59:59)
<b>Requested space region</b>	Altitude from 1515000.0 to 1535000.0 km; Latitude from -25.0 to 25.0 deg; Magnetic latitude from -35.0 to 35.0 deg; Distance to the Sun between 0.98 and 0.99 AU; Dipole $L$ value from 200.0 to 350.0 $R_e$ ; $Y_{GSE}$ component between -255000.0 and 255000.0 km.

4 Channels are matching your query.  
( **warning** = LOCATION FILTER NOT FULLY IMPLEMENTED )

<b>Channel list</b>	<input type="checkbox"/> Bmag_x_gse <Acemag@ACE> (Ace_mag_1h_txt#8) [details]
	<input type="checkbox"/> Bmag_y_gsm <Acemag@ACE> (Ace_mag_1h_txt#9) [details]
	<input type="checkbox"/> Bmag_z_gsm <Acemag@ACE> (Ace_mag_1h_txt#10) [details]
	<input type="checkbox"/> Bmag_norm <Acemag@ACE> (Ace_mag_1h_txt#11) [details]

Select desired channels...

**Data selection and retrieval tool**

Your workspace contains one entry

© BIRA/IASE, last update: 2001-Jul-31

# Status of the prototyping activity

- Level 1, the Yellow pages catalogue, has been fully implemented. The catalogue has been populated with many of the commonly used data provider services.
- In Level 2, different methods of data retrieval have been implemented through the FTP, SMTP and HTTP protocols. These have been applied to various data services, including GOES, ACE, Cluster, INTERMAGNET. In addition, an interface to trapped particle and atmospheric density models has been developed, and a link to SPENVIS (<http://www.spervis.oma.be/spervis/>) has been established. The Level 2 development retrieves data and results from model runs in a standardized ASCII format, which can be downloaded by the user via FTP. In addition, survey plots are generated automatically, which can also be downloaded.
- For Level 3, a number of « standard » orbital environments have been defined (which can be edited or extended by the user). The prototype is able to query its data base for those user selected parameters that are available for the selected orbital environment and time period. The link from this selection to the actual data retrieval via Level 2 has not yet been developed.
- A dynamic Web page ([http://eve.oma.be/ESWS/case\\_study/](http://eve.oma.be/ESWS/case_study/)) has been developed for the selected case study to show the orbital environment for a number of ESA spacecraft in orbit.
- The prototype has been used to provide input to WP432 by identifying the different problems which can be encountered with automated data retrieval.

# **Annex: Space Environment Yellow Pages**

**(June 2000)**

<b>ESWS</b>	Doc. No:	<b>WP 434 – BIRA-IASB</b>
	Issue:	Date: 6/14/00
Space Environment Yellow Pages	Author: MK	Page 1

## 1 Space Environment Yellow Pages

The SE Yellow Pages are a compilation of services, accessible through Internet, that provide useful resources to reconstruct the space environment at a particular place and time. The SE Yellow Pages correspond to level 1 of the prototyping activity of WP 434. Figure 1-I shows the prototyping logical model of which the components linked to the Yellow Pages have been highlighted. The Yellow Pages include cross-referenced catalogues of references to institutions maintaining servers with SE data or models, descriptions of satellite or ground missions related to the measurements of SE components, and parameters and physical quantities acting on the SE. The Yellow Pages also include information needed to retrieve and access the referenced data.

An overview of the different catalogues included in the Yellow Pages and their relation is shown on Figure 1-II. The main catalogues are:

- the SE Parameter catalogue that includes the description of the physical quantities used to characterize the natural SE, e.g. the electron thermal particle flux;
- the Data Service Catalogue that includes a list of providers of SE data archives or models, e.g. RAL WDC;
- the Model and Sensor Catalogue which refers to the space or ground based experiments, e.g. the UARS High Energy Particle Sensor.

The central point of the Yellow Pages architecture is the Channel Catalogue. Each entry of this catalogue corresponds to a unique data instance, i.e. a single physical quantity measured by a specific sensor on a specific mission and stored on a specific file. For instance, when a SE measurement is stored in several archives, different entries are introduced into the catalogue.

A detailed description of the catalogue structure is given in Sections 1.1, 1.2 and 1.3.

An example of catalogue entries is given in Section 1.4. It includes the complete description of the entries related to the SE measurements aboard GOES-8 satellite and their accessible archives.



<b>ESWS</b>	Doc. No:	<b>WP 434 – BIRA-IASB</b>
	Issue:	Date: 6/14/00
Space Environment Yellow Pages	Author: MK	Page 3

## **1.1 Space Environment Parameter Catalogue**

The SE Parameter Catalogue is a compilation of the parameters or physical quantities that are useful in the description of components of the natural SE. Each catalogue entry is related to a single quantity and includes, in addition to a short description, its standard unit, its range of validity, its type of data, and a list of meta-parameters on which it depends. Only two types of data are implemented: scalar and vector.

### **1.1.1 Meta-Parameters**

Some physical quantities depend on one or two meta-parameters. For instance the electron omnidirectional flux depends on energy, while debris fluxes depend on the particle mass and velocity. A catalogue is dedicated to these meta-parameters; its content is described in Table 1-A. A sample of meta-parameters is given in Table 1-B.

Note that the meta-parameter `NONE` is introduced as a placeholder.

### **1.1.2 Catalogue Entry Description**

The content of an entry for the SE parameter catalogue is given in Table 1-C. Note that only a maximum of two meta-parameters is allowed. Samples of entries are provided in the next sections.

### **1.1.3 Space Environment indices**

For different parts of the SE, several indices are introduced to appreciatively describe the state of the environment and to serve as input in models of this environment. The planetary magnetic activity index `Kp` or the ionospheric index `IF2` are examples of such indices. The SE indices are a particular case of SE parameters since they are not attached to a specific location and they are generally obtained from the compilation of a set of observations. A list of common SE indices is given in Table 1-D.

Since a same index can be defined over different time intervals (e.g. 3 hours or 1 day) that cannot be associated to a time resolution, a specific meta-parameter (`TIME_RNG`) has been introduced to allow the specification of these intervals. It is expressed in hours and can vary between 0 and 2184. See Section 1.1.5 for more information on the usage of the meta-parameter `TIME_RNG`.

<b>ESWS</b>	Doc. No: Issue:	<b>WP 434 – BIRA-IASB</b> Date: 6/14/00
	Space Environment Yellow Pages	Author: MK Page 4

**Table 1-A: Entry content for the meta-parameter catalogue**

<i>Record</i>	<i>Description or sample</i>
Pa_ID	Internal identification key
Pa_Name	Short name
Pa_Desc	Description of the meta-parameter
Pa_Unit	Meta parameter unit
Pa_MinV	Minimum valid value
Pa_MaxV	Maximum valid value

**Table 1-B: Sample of meta-parameter entries**

<i>Name</i>	<i>Description</i>	<i>Unit</i>	<i>Validity range</i>
NONE	No parameter	—	—
ENERG_ELE	Electron energy	keV	$10^{-3} - 10^{+6}$
ENERG_PRO	Proton energy	MeV	$10^{-3} - 10^{+6}$
WAVELENGTH	Photon wave length	nm	$10^{-3} - 10^{+3}$
MASS_DUST	Meteoroid or debris particle mass	g	$10^{-18} - 10^{+3}$

**Table 1-C: Entry content for the SE parameter catalogue**

<i>Record</i>	<i>Description or sample</i>
Md_ID	Internal identification key
Md_Name	Short name
Md_Desc	Description of the SE parameter or physical quantity
Md_Unit	Parameter unit
Md_MinV	Minimum valid value
Md_MaxV	Maximum valid value
Md_NbrP	Number of depending meta-parameters
Md_FstP	Pa_ID Key of the first meta-parameter
Md_SndP	Pa_ID Key of the second meta-parameter
Md_DtaT	Data type (scalar or vector)
Md_Help	URL reference to a general description of the parameter

<b>ESWS</b>	Doc. No:	<b>WP 434 – BIRA-IASB</b>
	Issue:	Date: 6/14/00
Space Environment Yellow Pages	Author: MK	Page 5

### 1.1.4 Example of Space Environment Parameters

To illustrate the use of the SE parameter catalogue, three entries related to the X-ray electromagnetic flux, the magnetic field and the satellite location are presented. The entries are summarized in Table 1-E.

The parameter `XRAY_FLUX` refers to the irradiance due to the X-ray part of the SE electromagnetic spectrum. Since the irradiance measurements can be related to different wavelength bands for different sensors, a dependence of the parameter `XRAY_FLUX` on the meta-parameter `WAVELENGTH` has been introduced.

The second entry of Table 1-E, the parameter `BMAG`, refers to the DC magnetic field present in the SE whatever the location, i.e. `BMAG` can refer either to the internal geomagnetic field, or to the magnetospheric magnetic field, or to the interplanetary magnetic field. The parameter `BMAG` is defined as a vector and can thus be used to refer to a given component of the field, as well as to its intensity. A short list of components associated to the `vector` data type is given in Table 1-F with examples of their application in the case of the SE magnetic field.

The last entry, the parameter `SATPOS`, is used internally for pseudo sensors to allow the retrieval of satellite ephemeris. In this case, the unit depends on the `POSITION` component, e.g. degrees for longitude, km for altitude, AU for distance from the Sun, ...

### 1.1.5 Structure Summary

The SE parameter catalogue depends on two sub-catalogues: one for the meta-parameters and one for the vector components. The links between these catalogues are illustrated on Figure 1-III. Each SE parameter only depends on zero, one or two meta-parameters. The SE parameters are related to components through the data type of both the parameter and the components. For scalar data, a placeholder component (`NONE`) is introduced.

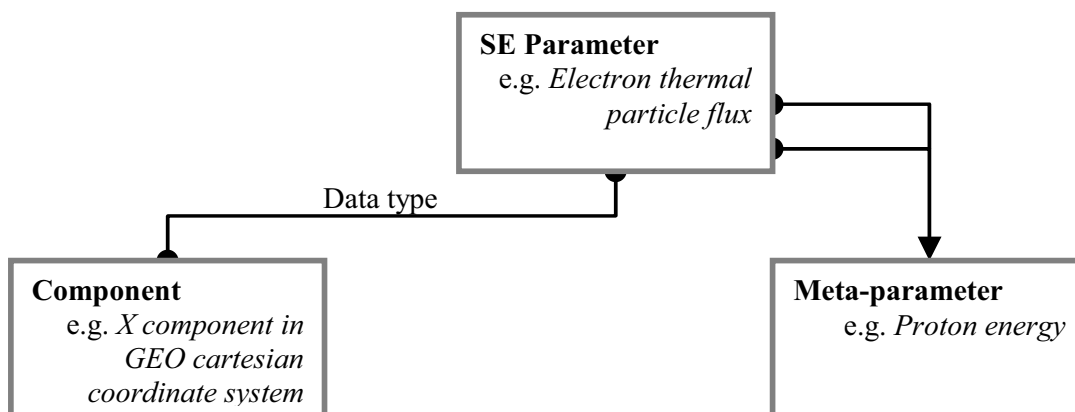

Figure 1-III: Structure of the SE parameter catalogue

<b>ESWS</b>	Doc. No:	<b>WP 434 – BIRA-IASB</b>
	Issue:	Date: 6/14/00
Space Environment Yellow Pages	Author: MK	Page 6

**Table 1-D: List of space environment indices**

Md_Name	Description	Unit	Validity range
AP	Planetary magnetic activity equivalent amplitude (Ap)	2 nT	0 – 400
KP	Planetary magnetic activity index (Kp)	1/10 <sup>†</sup>	0 – 90
F107	Ottawa 10.7 cm solar radio flux adjusted to 1 AU	10 <sup>-22</sup> J s <sup>-1</sup> m <sup>-2</sup> Hz <sup>-1</sup>	–
DST	Disturbance Storm-Time Index (Dst)	nT	–
SSN	International Sunspot number (Rz, Ri)		–
AE	Auroral Electrojet index (AE)	nT	–

**Table 1-E: Example of space environment parameters**

Md_Name	Description	Unit	Validity range	Dependence	Data Type
XRAY_FLUX	X-Ray radiant density flux	W m <sup>-2</sup>	10 <sup>-9</sup> – 1	WAVELENGTH	SCALAR
BMAG	DC Magnetic field	Gauss	10 <sup>-4</sup> – 10 <sup>-2</sup>	NONE	VECTOR
SATPOS	Spacecraft location	Arbitrary		NONE	POSITION

**Table 1-F: Illustration of vector components**

Co_Name	Description	Example of use
NORM	Strength or norm of the vector	The Earth's core geomagnetic field intensity deduced from the IGRF model
Z_GSM	Z component in the Geocentric Solar Magnetospheric cartesian coordinate system	The z-component of the interplanetary magnetic field measured aboard the WIND or IMP satellites
NADIR	Anti-radial component in a geocentric spherical coordinate system (GEO or GEI)	The Earthward component of the magnetospheric magnetic field measured by the GOES magnetometers

<sup>†</sup> The Kp index varies in 28 steps from 0 to 9. Following NOAA notations, the index will be translated in tenths of a unit and rounded: for instance, the values 3-, 3 and 3+ will be encoded as 27, 30 and 33, resp.

<b>ESWS</b>	Doc. No:	<b>WP 434 – BIRA-IASB</b>
	Issue:	Date: 6/14/00
Space Environment Yellow Pages	Author: MK	Page 7

## 1.2 Data Service Catalogue

The Data Service Catalogue is a compilation of institutions or science centres that provide access to SE data archives or models. The catalogue is limited to services that allow automatic data retrieval or model runs by simple access methods.

### 1.2.1 Access Methods

The access methods taken into account for the Data Service Catalogue are described and illustrated in Table 1-G. The `HTTP_GET` and `HTTP_SMTP` methods allows to automatically start a programme that evaluates a model or that applies a data reduction on the service server side. The `MANUAL` method refers to services that do not allow automatic retrieval but which are nevertheless included in the catalogue.

### 1.2.2 Catalogue Entry Description

The content of an entry for the data service catalogue is given in Table 1-H. It includes the specification of the service and of its related institute, the name of the responsible officer and of a contact person, a list of keywords and the access method. The keywords should allow a quick search in the data service catalogue and can be used to indicate some particularity of the service, such as the SE component addressed by the service, or data and model acronyms for which the service is the prime provider.

A same institute can be associated to more than one service

### 1.2.3 Source File Catalogue

Each service is assumed to provide SE data and model results by means of a single or set of files. For each kind of file that can be retrieve, a generic description of the location, name and structure of the file is compiled in the source file catalogue.

The content of an entry of this catalogue is summarized in Table 1-I. Since the description has to be generic, several records of the source file catalogue are “dynamic”, i.e. they include some parametric directives. The record `Fi_Durl` is one of these records: it contains a generic URL that generally depends on the requested date and time, and possibly on other parameters. For instance, for the 5-minute GOES-8 solar particle and electron flux data file which is available from the FTP server of NOAA/SEC, the record `Fi_Durl` can be written as:

[ftp://ftp.sel.noaa.gov/pub/lists/particle/\\${yyyy}\\${mm}\\${dd}\\_G8part\\_5m.txt](ftp://ftp.sel.noaa.gov/pub/lists/particle/${yyyy}${mm}${dd}_G8part_5m.txt)

where the character strings “`${yyyy}`”, “`${mm}`” and “`${dd}`” refer to the four-digit year, the two-digit month and the two-digit day of month of the requested date, respectively. The extensive description of the different directives will be given in Section XXX.

The period of time for which the files are normally available is included in the catalogue and can be specified either relative to a fixed date (e.g. the 1<sup>st</sup> of January 1950) or relative to the present time.

The five last records listed in Table 1-I (`Fi_Name`, `Fi_Chck`, `Fi_Copt`, `Fi_Read` and `Fi_Ropt`) are reserved for the Level-2 of the prototype and will be described later in Section XXX.

<b>ESWS</b>	Doc. No:	<b>WP 434 – BIRA-IASB</b>
	Issue:	Date: 6/14/00
Space Environment Yellow Pages	Author: MK	Page 8

**Table 1-G: List of access methods**

<i>Access method</i>	<i>Protocol used</i>	<i>Description</i>
HTTP_GET	Hyper-Text Transfer Protocol	<p>WWW-based access using a single request with a GET method, e.g.</p> <p><a href="http://rumba.gsfc.nasa.gov/cgi-bin/omniweb/dx1.cgi?activity=retrieve&amp;res=daily&amp;start_date=1999001&amp;end_date=1999031&amp;vars=23&amp;delivery_method=http">http://rumba.gsfc.nasa.gov/cgi-bin/omniweb/dx1.cgi?activity=retrieve&amp;res=daily&amp;start_date=1999001&amp;end_date=1999031&amp;vars=23&amp;delivery_method=http</a></p> <p>to retrieve daily averaged plasma temperature for January 1999 from the NSSDC Omniweb service.</p>
FTP_GET	File Transfer Protocol	<p>FTP-based access using a GET request, e.g.</p> <p><a href="ftp://ftp.sel.noaa.gov/pub/lists/particle/20000416_G8part_5m.txt">ftp://ftp.sel.noaa.gov/pub/lists/particle/20000416_G8part_5m.txt</a></p> <p>to retrieve 5-minute GOES-8 solar particle and electron flux for 16 April 2000 from the NOAA Space Environment Center.</p>
HTTP SMTP	Hyper-Text Transfer and Simple Mail Transfer Protocols	<p>WWW-based request (with a GET method) associated to a delivery by e-mail, e.g.</p> <p><a href="http://www.magnet.oma.be/htbin/unitst?limg=0,0&amp;lдат=1995.1.1.0,0&amp;lpos=800.,30.,40.,1&amp;email=myaddress@mysite.com">http://www.magnet.oma.be/htbin/unitst?limg=0,0&amp;lдат=1995.1.1.0,0&amp;lpos=800.,30.,40.,1&amp;email=myaddress@mysite.com</a></p> <p>to retrieve magnetic drift shell parameters for a given location and date from the UNILIB query page at IASB/BIRA.</p>
SMTP	Simple Mail Transfer Protocol	<p>One-way e-mail delivery of SE data, e.g. the automatic half-monthly distribution of indices by the account <a href="mailto:kp_index@gfz-potsdam.de">kp_index@gfz-potsdam.de</a> of the GeoForschungsZentrum (GFZ) Potsdam.</p>
MANUAL	Unknown	<p>WWW-based service access without automatic facility for data retrieval.</p>
LOCAL	None	<p>Placeholder for locally based models or data archive.</p>

<b>ESWS</b>	Doc. No:	<b>WP 434 – BIRA-IASB</b>
	Issue:	Date: 6/14/00
Space Environment Yellow Pages	Author: MK	Page 9

**Table 1-H: Entry content for the data service catalogue**

<i>Record</i>	<i>Description or sample</i>
Se_ID	Internal identification key
Se_Name	Short name of service, e.g. <i>CDAWeb</i>
Se_Desc	Full name of the service, e.g. <i>Coordinated Data Analysis (Workshop) Web</i>
Se_Accr	Acronym of the institution or centre providing the service, e.g. <i>SPDF</i> .
Se_Orga	Full name of the institution, e.g. <i>NASA/GSFC Space Physics Data Facility</i>
Se_Addr	Address
Se_Head	Title, first and last name of the responsible person
Se_Tech	Title, first and last name of the contact person for technical assistance
Se_Emai	E-mail of the contact person
Se_Home	URL to the home page of the institute
Se_Help	URL to online documentation about the service
Se_Keyw	List of keywords related to the SE components and data addressed by the service, e.g. <i>meteoroids, ISTP, ...</i>
Se_Meth	Access method, see Table 1-G
Se_Nice	Level of relevance for SE characterization.

**Table 1-I: Entry content for the source file catalogue**

<i>Record</i>	<i>Description or sample</i>
Fi_ID	Internal identification key
Fi_Desc	Generic description of the files
Fi_Serv	se_ID Key of the service
Fi_Durl	“Dynamic” URL needed to access the files
Fi_Epoc	Type of period over which the files are accessible, e.g. <i>MJD1950</i> or <i>PRESENT</i> .
Fi_Star	Starting time of the accessibility period (in days)
Fi_Stop	Stopping time of the accessibility period (in days)
Fi_Ncol	Number of parameters (or columns) included in each file
Fi_Tres	Smallest time resolution of the file (in seconds)
Fi_Name	“Dynamic” local name and location
Fi_Chck	Reference to the file verification routine
Fi_Copt	“Dynamic” option string to be passed to the verification routine
Fi_Read	Reference to the file reading routine
Fi_Ropt	“Dynamic” option string to be passed to the reading routine

<b>ESWS</b>	Doc. No:	<b>WP 434 – BIRA-IASB</b>
	Issue:	Date: 6/14/00
Space Environment Yellow Pages	Author: MK	Page 10

### **1.3 Model and Sensor Catalogue**

The Model and Sensor Catalogue is a compilation of the accessible experimental data and model tools relevant to the determination of the SE. The experimental data are grouped by detector and by satellite (or ground station). Each set of measurements (or simulations) of a SE parameter is identified as a channel. Each channel is associated to a single detector, which is also associated to a single satellite. For identical instruments aboard of different satellites, separate entries have to be introduced accordingly into the Sensor catalogue.

#### **1.3.1 Catalogue Entry Description**

Table 1-J

#### **1.3.2 Channel Catalogue**

Table 1-K

#### **1.3.3 Mission Catalogue**

Table 1-L

#### **1.3.4 Structure Summary**

Figure 1-IV

<b>ESWS</b>	Doc. No:	<b>WP 434 – BIRA-IASB</b>
	Issue:	Date: 6/14/00
Space Environment Yellow Pages	Author: MK	Page 11

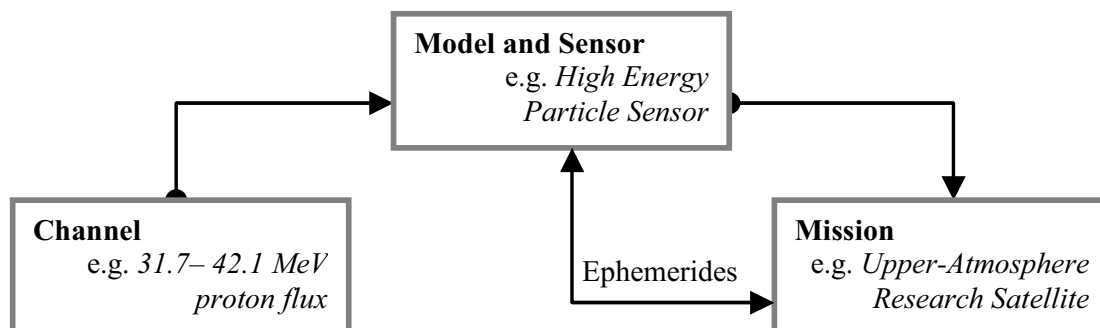

**Figure 1-IV: Structure of the model and sensor catalogue**

**Table 1-J: Entry content for the model and sensor catalogue**

<i>Record</i>	<i>Description or sample</i>
De_ID	Internal identification key
De_Name	Short name of the sensor, e.g. PEM/HEPS
De_Desc	Description of the sensor, e.g. <i>High Energy Particle Sensor (Particle Environment Monitor)</i>
De_Info	Additional information about the sensor
De_Nchn	Number of channels
De_Head	Title, initials and last name of the Principal Investigator
De_Orga	Name of the PI's institute or organisation
De_Emai	E-mail
De_Addr	Postal address
De_Home	URL to the home page of the institute
De_Help	URL to online documentation about the sensor
De_Mcat	Identification key of the NSSDC master catalogue, e.g. <i>91-063B-07</i>
De_Refe	Selected reference to published documentation on the sensor
De_Miss	Mi_ID Key of the satellite or ground station
De_Tres	Smallest time resolution (in seconds)
De_Keyw	List of keywords related to the sensor
De_Extr	Reference to the data extrapolation routine
De_Eopt	“Dynamic” option string to be passed to the extrapolation routine
De_Anci	Reference to the routine listing ancillary sensors needed for data extraction.
De_Aopt	“Dynamic” option string to be passed to the ancillary routine

<b>ESWS</b>	Doc. No:	<b>WP 434 – BIRA-IASB</b>
	Issue:	Date: 6/14/00
Space Environment Yellow Pages	Author: MK	Page 12

**Table 1-K: Entry content for the channel catalogue**

<i>Record</i>	<i>Description or sample</i>
Ch_ID	Internal identification key
Ch_Detc	De_ID Key of the model or sensor
Ch_Srce	Fi_ID Key of the generic file description (see Table 1-I)
Ch_Indx	Corresponding column index in the data file
Ch_Data	Md_ID Key of the measured SE parameter (see in Table 1-C)
Ch_Mult	Multiplicative factor to apply on the data (unit conversion)
Ch_Comp	Name of the measured component
Ch_P1Lo	Lower limit of the range for the first meta-parameter
Ch_P1Hi	Upper limit of the range for the first meta-parameter
Ch_P2Lo	Lower limit of the range for the second meta-parameter
Ch_P2Hi	Upper limit of the range for the second meta-parameter
Ch_Nice	Level of quality

**Table 1-L: Entry content for the mission catalogue**

<i>Record</i>	<i>Description or sample</i>
Mi_ID	Internal identification key
Mi_Name	Short name of the satellite, ground mission or model
Mi_Desc	Description of the mission
Mi_Type	Type of mission, e.g. <i>MODEL</i> , <i>SPACE</i> , <i>GROUND</i> ...
Mi_Head	Title, first and last name of the Principal Investigator
Mi_Orga	Name of the PI's institute or organisation
Mi_Emai	E-mail
Mi_Addr	Postal address
Mi_Home	URL to the home page of the institute
Mi_Help	URL to online documentation about the sensor
Mi_Mcat	International designation (i.e. NSSDC master catalogue ID)
Mi_Refe	Selected reference to published documentation
Mi_Rang	Set of coordinate ranges delimitating the zone of space addressed by the mission
Mi_Ephe	For space mission, De_ID key of the pseudo-sensor related to ephemerid data
Mi_Intr	Reference to the location interpolation routine
Mi_Iopt	Option to be passed to the interpolation routine
Mi_Delt	Time interval needed for the interpolation (in days)

<b>ESWS</b>	Doc. No:	<b>WP 434 – BIRA-IASB</b>
	Issue:	Date: 6/14/00
Space Environment Yellow Pages	Author: MK	Page 13

## 1.4 Example: GOES-8 data

The geosynchronous GOES-8 satellite is part of NASA-developed, NOAA operated, meteorological spacecrafts. It carries:

- an Imager and Sounder system to provide visible and infrared images of cloud cover, and to determine atmospheric temperature and water vapour content at various levels;
- a meteorological data collection system to relay processed data from central weather facilities to regional stations equipped with APT (Automatic Picture Transmission) and to collect and retransmit data from remotely located Earth-based platforms;
- a Space Environment Monitor (SEM) system to measure proton, electron and solar X-ray fluxes and magnetic fields;
- a Search and Rescue (SAR) system to detect and relay distress calls from land and ocean; and
- a WEFAX (weather facsimile) system to disseminate weather information to the user community via fax.

In the framework of the SE Yellow Pages, only the data relative to the SEM instrument and the satellite location will be taken into account.

The data for the mission entry are: (see Table 1-L)

Mi\_Name: GOES-8  
 Mi\_Desc: NASA/NOAA Geostationary Operational Environmental Satellite – 8  
 Mi\_Type: SPACE  
 Mi\_Head: Dr. R. D. Zwickl  
 Mi\_Orga: SEL/NOAA Environmental Research Labs  
 Mi\_Emai: unknown  
 Mi\_Addr: Code R/E/SE, 325 Broadway, Boulder, CO 80303-3328, USA  
 Mi\_Home: <http://www.sel.noaa.gov/>  
 Mi\_Help: <http://rsd.gsfc.nasa.gov/goesb/chesters/web/text/goes.databook.html>  
 Mi\_Mcat: 94-022A  
 Mi\_Refe: GOES I-M DataBook, Space Systems Loral, DRL 101-08 Revision 1, GSFC Ref #S-415-19, 31 August 1996  
 Mi\_Rang: *predefined values for geostationary satellites (see Section XXX)*  
 Mi\_Ephe: see later

### 1.4.1 Data Provider Services

Different services that provide GOES-8 data have been identified: (see Table 1-C)

#### 1. The Space Physics Interactive Data Resource (SPIDR)

Se\_Name: SPIDR  
 Se\_Desc: Space Physics Interactive Data Resource  
 Se\_Accr: NGDC/STP  
 Se\_Orga: Solar Terrestrial Physics Division of the NOAA National Geophysical Data Center

<b>ESWS</b>	Doc. No:	<b>WP 434 – BIRA-IASB</b>
	Issue:	Date: 6/14/00
Space Environment Yellow Pages	Author: MK	Page 14

Se\_Addr: Code E/GC2, 325 Broadway, Boulder, CO 80303-3328, USA  
 Se\_Head: Dr. H. W. Kroehl  
 Se\_Tech: Mr. C. A. Clark  
 Se\_Emai: cclark@ngdc.noaa.gov  
 Se\_Home: <http://www.ngdc.noaa.gov/stp/stp.html>  
 Se\_Help: <http://spidr.ngdc.noaa.gov:8080/>  
 Se\_Keyw:  
 Se\_Meth: MANUAL and HTTP\_GET

## 2. The Coordinated Data Analysis Web (CDAWeb)

Se\_Name: CDAWeb  
 Se\_Desc: Coordinated Data Analysis Web  
 Se\_Accr: SPDF  
 Se\_Orga: NASA/GSFC Space Physics Data Facility  
 Se\_Addr: NASA/Goddard Space Flight Center, Greenbelt, MD 20771, USA  
 Se\_Head: Dr. R. E. McGuire  
 Se\_Tech: Mr. T. Kovalick  
 Se\_Emai: kovalick@nssdc.gsfc.nasa.gov  
 Se\_Home: <http://nssdc.gsfc.nasa.gov/spdf/>  
 Se\_Help: <http://cdaweb.gsfc.nasa.gov/cdaweb/help.html>  
 Se\_Keyw:  
 Se\_Meth: MANUAL and FTP\_GET

## 3. The gopher site of NOAA Space Environment Center

Se\_Name: SEC-GOPH  
 Se\_Desc: Space Environment Center Gopher system  
 Se\_Accr: SEC  
 Se\_Orga: NOAA Space Environment Center  
 Se\_Addr: Code E/GC2, 325 Broadway, Boulder, CO 80303-3328, USA  
 Se\_Head: E. Hildner  
 Se\_Tech: Mrs. V. Raben  
 Se\_Emai: vraben@sec.noaa.gov  
 Se\_Home: <http://www.sec.noaa.gov>  
 Se\_Help: [gopher://solar.sec.noaa.gov:70/00/welcome/gopher\\_over](gopher://solar.sec.noaa.gov:70/00/welcome/gopher_over)  
 Se\_Keyw:  
 Se\_Meth: HTTP\_GET

## 4. The ftp site of the NOAA Space Environment Center

Se\_Name: SEC-FTP  
 Se\_Desc: Space Environment Center anonymous FTP system  
 Se\_Tech: R. T. DeFoor  
 Se\_Emai: tdefoor@sec.noaa.gov  
 Se\_Help: [ftp://ftp.sel.noaa.gov/pub/welcome/ftp\\_over.txt](ftp://ftp.sel.noaa.gov/pub/welcome/ftp_over.txt)  
 Se\_Keyw:  
 Se\_Meth: FTP\_GET

## 5. The Space Environment Information System

Se\_Name: SPENVIS

<b>ESWS</b>	Doc. No:	<b>WP 434 – BIRA-IASB</b>
	Issue:	Date: 6/14/00
Space Environment Yellow Pages	Author: MK	Page 15

Se\_Desc: ESA/ESTEC Space Environment Information System  
 Se\_Accr: BISA/FD  
 Se\_Orga: Fundamental Dynamics division of the Belgian Institute for Space  
 Aeronomy (BIRA-IASB)  
 Se\_Addr: Ringlaan 3, B-1180 Brussels, Belgium  
 Se\_Head: Pr. J. L. Lemaire  
 Se\_Tech: Mr. B. Quaghebeur  
 Se\_Emai: B.Quaghebeur@oma.be  
 Se\_Home: <http://www.magnet.oma.be/>  
 Se\_Help: <http://www.spennis.oma.be/spennis/help/system/spennis.html>  
 Se\_Keyw:  
 Se\_Meth: MANUAL

The different services do not provide exactly the same data sets and do not cover the same period of time. Be aware that inconsistencies between data sets from different services may occur. Note that the SPENVIS and SPIDR systems do not provide an easy interface to implement automatic retrieval of the GOES data.

#### 1.4.2 GOES-8 SEM Solar X-ray Monitor

The data for the sensor entry relative to the X-ray monitor are: (see Table 1-J)

De\_Name: GOES-8/XRS  
 De\_Desc: Solar X-ray Monitor (GOES-8 Space Environment Monitor)  
 De\_Info: Two ion chambers behind lead-lined aluminium collimators with Be  
 apertures and filled with Xe-He and Ar-He mixture, respectively.  
 De\_Nchn: 2  
 De\_Head: Mr. H. A. Garcia  
 De\_Orga: SEL/NOAA Environmental Research Labs  
 De\_Emai:  
 De\_Addr: Code R/E/SE, 325 Broadway, Boulder, CO 80303-3328, USA  
 De\_Home: <http://www.sel.noaa.gov/>  
 De\_Help: <http://rsd.gsfc.nasa.gov/goesb/chesters/web/text/databook/section05.pdf>  
 De\_Mcat: 94-022A-03  
 De\_Refe:  
 De\_Tres: 0.512  
 De\_Keyw:

The GOES-8/XRS sensor provides data on the SE parameter XRAY\_FLUX, which is described in Table 1-E and depends on the photon wavelength expressed in nanometers. Two data files are related to this sensor: (see Table 1-I)

##### 1. 1-minute GOES-8 Solar X-ray Flux on the Space Environment Center FTP site

Fi\_Desc: 1-minute average of GOES-8 Solar X-ray Flux (ascii file)  
 Fi\_Serv: SEC-FTP  
 Fi\_Durl: [ftp://ftp.sel.noaa.gov/pub/lists/xray/\\${yyyy}/\\${mm}/\\${dd}\\_G8xr\\_1m.txt](ftp://ftp.sel.noaa.gov/pub/lists/xray/${yyyy}/${mm}/${dd}_G8xr_1m.txt)  
 Fi\_Epoc: PRESENT  
 Fi\_Star: -16.0 (only the last 15 days are archived)  
 Fi\_Stop: -1.0 (yesterday)

<b>ESWS</b>	Doc. No:	<b>WP 434 – BIRA-IASB</b>
	Issue:	Date: 6/14/00
Space Environment Yellow Pages	Author: MK	Page 16

Fi\_Ncol: 8

Fi\_Tres: 60.0

## 2. 5-minute GOES-8 Solar X-ray Flux on the Space Environment Center FTP site

Fi\_Desc: 5-minute average of GOES-8 Solar X-ray Flux (ascii file)

Fi\_Serv: SEC-FTP

Fi\_Durl: [ftp://ftp.sel.noaa.gov/pub/lists/xray/\\${yyyy}/\\${mm}/\\${dd}\\_G8xr\\_5m.txt](ftp://ftp.sel.noaa.gov/pub/lists/xray/${yyyy}/${mm}/${dd}_G8xr_5m.txt)

Fi\_Epoc: PRESENT

Fi\_Star: -46.0 (only the last 45 days are archived)

Fi\_Stop: -1.0 (yesterday)

Fi\_Ncol: 8

Fi\_Tres: 300.0

Both files are also available through the Space Environment Center Gopher site at

Fi\_Durl: [gopher://solar.sec.noaa.gov:70/11/lists/xray/\\${yyyy}/\\${mm}/\\${dd}\\_G8xr\\_1m](gopher://solar.sec.noaa.gov:70/11/lists/xray/${yyyy}/${mm}/${dd}_G8xr_1m)

Fi\_Durl: [gopher://solar.sec.noaa.gov:70/11/lists/xray/\\${yyyy}/\\${mm}/\\${dd}\\_G8xr\\_5m](gopher://solar.sec.noaa.gov:70/11/lists/xray/${yyyy}/${mm}/${dd}_G8xr_5m)

respectively. These files could also be introduced by means of an equivalence catalogue but they are not considered in this example. The same situation occurs for the other files from the NOAA/SEC FTP site.

Since each file includes data on both channels of the X-ray monitor, four channel entries are defined: (see Table 1-K)

### A. 1-minute average 0.05–0.4 nanometer channel

Ch\_Detc: GOES-8/XRS

Ch\_Srce: "...G8xr\_1m.txt"

Ch\_Indx: 7

Ch\_Data: XRAY\_FLUX (X-Ray radiant density flux)

Ch\_Mult: 1.0

Ch\_Comp: NONE

Ch\_P1Lo: 0.05 (photon wave length lower limit in nm)

Ch\_P1Hi: 0.4 (photon wave length upper limit in nm)

### B. 1-minute average 0.1–0.8 nanometer channel

Ch\_Detc: GOES-8/XRS

Ch\_Srce: "...G8xr\_1m.txt"

Ch\_Indx: 8

Ch\_Data: XRAY\_FLUX (X-Ray radiant density flux)

Ch\_Mult: 1.0

Ch\_Comp: NONE

Ch\_P1Lo: 0.1 (photon wave length lower limit in nm)

Ch\_P1Hi: 0.8 (photon wave length lower limit in nm)

### C. 5-minute average 0.05–0.4 nanometer channel

Ch\_Detc: GOES-8/XRS

Ch\_Srce: "...G8xr\_5m.txt"

Ch\_Indx: 7

Ch\_Data: XRAY\_FLUX (X-Ray radiant density flux)

Ch\_Mult: 1.0

Ch\_Comp: NONE

<b>ESWS</b>	Doc. No:	<b>WP 434 – BIRA-IASB</b>
	Issue:	Date: 6/14/00
Space Environment Yellow Pages	Author: MK	Page 17

Ch\_P1Lo: 0.05 (photon wave length lower limit in nm)  
Ch\_P1Hi: 0.4 (photon wave length lower limit in nm)

**D. 5-minute average 0.1–0.8 nanometer channel**

Ch\_Detc: GOES-8/XRS  
Ch\_Srce: "...G8xr\_5m.txt"  
Ch\_Indx: 8  
Ch\_Data: XRAY\_FLUX (X-Ray radiant density flux)  
Ch\_Mult: 1.0  
Ch\_Comp: NONE  
Ch\_P1Lo: 0.1 (photon wave length lower limit in nm)  
Ch\_P1Hi: 0.8 (photon wave length upper limit in nm)

**1.4.3 GOES-8 SEM Triaxial Fluxgate Magnetometer**

The data for the sensor entry relative to the magnetometer are: (see Table 1-J)

De\_Name: GOES-8/TFM  
De\_Desc: Triaxial Fluxgate Magnetometer (GOES-8 Space Environment Monitor)  
De\_Info: Two redundant sets of three orthogonal flux gate magnetometer elements mounted on a 3-meters boom, about 1 nT of accuracy.  
De\_Nchn: 3  
De\_Head: Dr. H. J. Singer  
De\_Orga: SEL/NOAA Environmental Research Labs  
De\_Emai: hsinger@sel.noaa.gov  
De\_Addr: Code R/E/SE, 325 Broadway, Boulder, CO 80303-3328, USA  
De\_Home: <http://www.sel.noaa.gov/>  
De\_Help: <http://rsd.gsfc.nasa.gov/goesb/chesters/web/text/databook/section05.pdf>  
De\_Mcat: 94-022A-04  
De\_Refe: Singer, H.J., L. Matheson, R. Grubb, A. Newman and S.D. Bouwer, Monitoring Space Weather with the GOES Magnetometers, SPIE Conference Proceedings, Volume 2812, 4-9 August 1996  
De\_Tres: 0.512  
De\_Keyw:

The GOES-8/TFM sensor provides data on the SE parameter BMAG, described in Table 1-E. According to data source, different components of the magnetic field can be addressed:

Z\_GEO: z-component in geocentric coordinate system, i.e. component parallel to the Earth's spin axis;  
NADIR: Anti-radial component in a geocentric coordinate system, i.e. Earthwards component;  
P\_GEO: φ-component in a geocentric spherical coordinate system, i.e. geographic eastwards component;  
NORM: strength of the vector, i.e. total field;  
X\_GSE: x-component in GSE, GSEQ and GSM coordinate systems, i.e. component parallel to the Earth-Sun axis;

<b>ESWS</b>	Doc. No:	<b>WP 434 – BIRA-IASB</b>
	Issue:	Date: 6/14/00
Space Environment Yellow Pages	Author: MK	Page 18

Y\_GSE: y-component in geocentric solar ecliptic coordinate (GSE) system, i.e. component in the ecliptic plane pointing towards dusk;

Z\_GSE: z-component in geocentric solar ecliptic coordinate (GSE) system, i.e. component perpendicular to the ecliptic plane;

Y\_GSM: y-component in the geocentric solar magnetospheric (GSM) system, i.e. perpendicular to both the Earth's magnetic dipole axis and the Earth-Sun axis;

Z\_GSM: z-component in the geocentric solar magnetospheric (GSM) system.

Two generic data files are related to the GOES-8/TFM sensor: (see Table 1-I)

### 1. 1-minute GOES-8 Geomagnetic Field Components on the Space Environment Center FTP site

Fi\_Desc: 1-minute average of GOES-8 Geomagnetic Field (ascii file)

Fi\_Serv: SEC-FTP

Fi\_Durl: [ftp://ftp.sel.noaa.gov/pub/lists/geomag/\\${yyyy}/\\${mm}/\\${dd}\\_G8mag\\_1m.txt](ftp://ftp.sel.noaa.gov/pub/lists/geomag/${yyyy}/${mm}/${dd}_G8mag_1m.txt)

Fi\_Epoc: PRESENT

Fi\_Star: -36.0 (only the last 35 days are archived)

Fi\_Stop: -1.0 (yesterday)

Fi\_Ncol: 10

Fi\_Tres: 60.0

### 2. GOES 8 Magnetometer Key Parameters on the Coordinated Data Analysis Web FTP site

Fi\_Desc: 1-minute average of GOES-8 Magnetometer Key Parameters (cdf file)

Fi\_Serv: CDASWeb

Fi\_Durl: [ftp://cdaweb.gsfc.nasa.gov/pub/istp/goes/8\\_mag/\\${yyyy}/g8\\_k0\\_mag\\_\\${yyyy}/\\${mm}/\\${dd}\\_v\\${cdfver}.cdf](ftp://cdaweb.gsfc.nasa.gov/pub/istp/goes/8_mag/${yyyy}/g8_k0_mag_${yyyy}/${mm}/${dd}_v${cdfver}.cdf)

Fi\_Epoc: MJD1950-PRESENT

Fi\_Star: ????? (2 December 1995)

Fi\_Stop: -1.0 (yesterday)

Fi\_Ncol: 72 (24 regular variables of dimension 3)

Fi\_Tres: 60.0

The channels associated to both files are: (see Table 1-K)

#### A. 1-minute average Hp component

Ch\_Detc: GOES-8/TFM

Ch\_Srce: "...G8mag\_1m.txt"

Ch\_Indx: 7

Ch\_Data: BMAG (Magnetic field)

Ch\_Mult:  $10^{-5}$  (nT)

Ch\_Comp: Z\_GEO

#### B. 1-minute average He component

Ch\_Detc: GOES-8/TFM

Ch\_Srce: "...G8mag\_1m.txt"

Ch\_Indx: 8

Ch\_Data: BMAG (Magnetic field)

Ch\_Mult:  $10^{-5}$  (nT)

<b>ESWS</b>	Doc. No:	<b>WP 434 – BIRA-IASB</b>
	Issue:	Date: 6/14/00
Space Environment Yellow Pages	Author: MK	Page 19

Ch\_Comp: NADIR

**C. 1-minute average Hn component**

Ch\_Detc: GOES-8/TFM  
 Ch\_Srce: "...G8mag\_1m.txt"  
 Ch\_Indx: 9  
 Ch\_Data: BMAG (Magnetic field)  
 Ch\_Mult:  $10^{-5}$  (nT)  
 Ch\_Comp: P\_GEO

**D. 1-minute average Total Field**

Ch\_Detc: GOES-8/TFM  
 Ch\_Srce: "...G8mag\_1m.txt"  
 Ch\_Indx: 10  
 Ch\_Data: BMAG (Magnetic field)  
 Ch\_Mult:  $10^{-5}$  (nT)  
 Ch\_Comp: NORM

**E. ISTP key parameter X-GSE component**

Ch\_Detc: GOES-8/TFM  
 Ch\_Srce: "...g8\_k0\_mag....cdf"  
 Ch\_Indx: 7 (1<sup>st</sup> element of B\_GSE\_c)  
 Ch\_Data: BMAG (Magnetic field)  
 Ch\_Mult:  $10^{-5}$  (nT)  
 Ch\_Comp: X\_GSE

**F. ISTP key parameter Y-GSE component**

Ch\_Detc: GOES-8/TFM  
 Ch\_Srce: "...g8\_k0\_mag....cdf"  
 Ch\_Indx: 8 (2<sup>nd</sup> element of B\_GSE\_c)  
 Ch\_Data: BMAG (Magnetic field)  
 Ch\_Mult:  $10^{-5}$  (nT)  
 Ch\_Comp: Y\_GSE

**G. ISTP key parameter Z-GSE component**

Ch\_Detc: GOES-8/TFM  
 Ch\_Srce: "...g8\_k0\_mag....cdf"  
 Ch\_Indx: 9 (3<sup>rd</sup> element of B\_GSE\_c)  
 Ch\_Data: BMAG (Magnetic field)  
 Ch\_Mult:  $10^{-5}$  (nT)  
 Ch\_Comp: Z\_GSE

**H. ISTP key parameter X-GSM component**

Ch\_Detc: GOES-8/TFM  
 Ch\_Srce: "...g8\_k0\_mag....cdf"  
 Ch\_Indx: 10 (1<sup>st</sup> element of B\_GSM\_c)  
 Ch\_Data: BMAG (Magnetic field)  
 Ch\_Mult:  $10^{-5}$  (nT)  
 Ch\_Comp: X\_GSE

**I. ISTP key parameter Y-GSM component**

<b>ESWS</b>	Doc. No:	<b>WP 434 – BIRA-IASB</b>
	Issue:	Date: 6/14/00
Space Environment Yellow Pages	Author: MK	Page 20

Ch\_Detc: GOES-8/TFM  
 Ch\_Srce: "...g8\_k0\_mag....cdf"  
 Ch\_Indx: 11 (2<sup>nd</sup> element of B\_GSM\_c)  
 Ch\_Data: BMAG (Magnetic field)  
 Ch\_Mult: 10<sup>-5</sup> (nT)  
 Ch\_Comp: Y\_GSM

**J. ISTP key parameter Z-GSM component**

Ch\_Detc: GOES-8/TFM  
 Ch\_Srce: "...g8\_k0\_mag....cdf"  
 Ch\_Indx: 12 (3<sup>rd</sup> element of B\_GSM\_c)  
 Ch\_Data: BMAG (Magnetic field)  
 Ch\_Mult: 10<sup>-5</sup> (nT)  
 Ch\_Comp: Z\_GSM

**K. ISTP key parameter s/c He component**

Ch\_Detc: GOES-8/TFM  
 Ch\_Srce: "...g8\_k0\_mag....cdf"  
 Ch\_Indx: 13 (1<sup>st</sup> element of B\_lcl\_c)  
 Ch\_Data: BMAG (Magnetic field)  
 Ch\_Mult: 10<sup>-5</sup> (nT)  
 Ch\_Comp: NADIR

**L. ISTP key parameter s/c Hn component**

Ch\_Detc: GOES-8/TFM  
 Ch\_Srce: "...g8\_k0\_mag....cdf"  
 Ch\_Indx: 14 (1<sup>st</sup> element of B\_lcl\_c)  
 Ch\_Data: BMAG (Magnetic field)  
 Ch\_Mult: 10<sup>-5</sup> (nT)  
 Ch\_Comp: P\_GEO

**M. ISTP key parameter s/c Hp component**

Ch\_Detc: GOES-8/TFM  
 Ch\_Srce: "...g8\_k0\_mag....cdf"  
 Ch\_Indx: 15 (1<sup>st</sup> element of B\_lcl\_c)  
 Ch\_Data: BMAG (Magnetic field)  
 Ch\_Mult: 10<sup>-5</sup> (nT)  
 Ch\_Comp: Z\_GEO

Note that some pairs of channels refer to exactly the same data. This is the case for the pairs (A,M), (B,K), (C,L) and (E,H).

#### 1.4.4 GOES-8 SEM Energetic Particle Sensor

The data for the sensor entry relative to the energetic particle sensor are:

De\_Name: GOES-8/EPS  
 De\_Desc: Energetic Particle Sensor (GOES-8 Space Environment Monitor)  
 De\_Info: Combination of, a dome with three sets of two Si surface barrier detectors covered by different thickness moderators, a Tg-shielded

<b>ESWS</b>	Doc. No:	<b>WP 434 – BIRA-IASB</b>
	Issue:	Date: 6/14/00
Space Environment Yellow Pages	Author: MK	Page 21

telescope (EP8) with two other Si surface barrier detectors, and a Cerenkov counter (HEPAD).

De\_Nchn: 27  
 De\_Head: Dr. H. H. Sauer  
 De\_Orga: SEL/NOAA Environmental Research Labs  
 De\_Emai: hsauer@sel.noaa.gov  
 De\_Addr: Code R/E/SE, 325 Broadway, Boulder, CO 80303-3328, USA  
 De\_Home: <http://www.sel.noaa.gov/>  
 De\_Help: <http://rsd.gsfc.nasa.gov/goesb/chesters/web/text/databook/section05.pdf>  
 De\_Mcat: 94-022A-05  
 De\_Refe:  
 De\_Tres: 10.2  
 De\_Keyw:

The GOES-8/EPS sensor provides data on different SE parameters:

EUI\_FLUX: unidirectional integral electron flux, in  $\text{cm}^{-2}\text{sr}^{-1}\text{s}^{-1}$  and depending on the meta-parameter ENERG\_ELE (see Table 1-B)  
 PUI\_FLUX: unidirectional integral proton flux, in  $\text{cm}^{-2}\text{sr}^{-1}\text{s}^{-1}$  and depending on the meta-parameter ENERG\_PRO (see Table 1-B)  
 PUD\_FLUX: unidirectional differential proton flux, in  $\text{cm}^{-2}\text{sr}^{-1}\text{keV}^{-1}\text{s}^{-1}$  and depending on the meta-parameter ENERG\_PRO (see Table 1-B)

All the particle fluxes depend on an energy range. For the differential flux, the energy range corresponds to the limits of the corresponding channel. For the integral fluxes, the upper energy corresponds to the last particle energy detected by the sensor. Note that none of the alpha channels is archived.

The generic data files related to the GOES-8/EPS sensor are: (see Table 1-I)

### 1. 5-minute GOES-8 Energetic Proton Flux Channels on the Space Environment Center FTP site

Fi\_Desc: 5-minute GOES-8 Energetic Proton Flux Channels (uncorrected, ascii file)  
 Fi\_Serv: SEC-FTP  
 Fi\_Durl: [ftp://ftp.sel.noaa.gov/pub/lists/pchan/\\${yyyy}/\\${mm}/\\${dd}\\_G8pchan\\_5m.txt](ftp://ftp.sel.noaa.gov/pub/lists/pchan/${yyyy}/${mm}/${dd}_G8pchan_5m.txt)  
 Fi\_Epoc: PRESENT  
 Fi\_Star: -46.0 (only the last 45 days are archived)  
 Fi\_Stop: -1.0 (yesterday)  
 Fi\_Ncol: 17  
 Fi\_Tres: 300.0

### 2. 5-minute GOES-8 Solar Particle and Electron Flux on the Space Environment Center FTP site

Fi\_Desc: 5-minute GOES-8 Solar Particle and Electron Flux (ascii file)  
 Fi\_Serv: SEC-FTP  
 Fi\_Durl: [ftp://ftp.sel.noaa.gov/pub/lists/particle/\\${yyyy}/\\${mm}/\\${dd}\\_G8part\\_5m.txt](ftp://ftp.sel.noaa.gov/pub/lists/particle/${yyyy}/${mm}/${dd}_G8part_5m.txt)  
 Fi\_Epoc: PRESENT  
 Fi\_Star: -46.0 (only the last 45 days are archived)  
 Fi\_Stop: -1.0 (yesterday)

<b>ESWS</b>	Doc. No:	<b>WP 434 – BIRA-IASB</b>
	Issue:	Date: 6/14/00
Space Environment Yellow Pages	Author: MK	Page 22

Fi\_Ncol: 17

Fi\_Tres: 300.0

### 3. Last 30 Days Daily Particle Data on the Space Environment Center FTP site

Fi\_Desc: Last 30 Days Daily Particle Data (ascii file)

Fi\_Serv: SEC-FTP

Fi\_Durl: <ftp://ftp.sel.noaa.gov/pub/latest/DPD.txt>

Fi\_Epoc: PRESENT

Fi\_Star: -31.0 (only the last 30 days are archived)

Fi\_Stop: -1.0 (yesterday)

Fi\_Ncol: 9

Fi\_Tres: 3600.0

### 4. GOES 8 Energetic Particle Key Parameters on the Coordinated Data Analysis Web FTP site

Fi\_Desc: 1-minute average of GOES-8 Energetic Particle Key Parameters (cdf file)

Fi\_Serv: CDAWeb

Fi\_Durl: [ftp://cdaweb.gsfc.nasa.gov/pub/istp/goes/8\\_ep8/\\${yyyy}/g8\\_k0\\_ep8\\_\\${yyyy}\\${mm}\\${dd}\\_v\\${cdfver}.cdf](ftp://cdaweb.gsfc.nasa.gov/pub/istp/goes/8_ep8/${yyyy}/g8_k0_ep8_${yyyy}${mm}${dd}_v${cdfver}.cdf)

Fi\_Epoc: MJD1950-PRESENT

Fi\_Star: ????? (2 December 1995)

Fi\_Stop: -1.0 (yesterday)

Fi\_Ncol: 75 (25 regular variables of dimension 3)

Fi\_Tres: 60.0

The channels associated to these files are: (see Table 1-K)

#### A. GOES Electron Flux > 0.6 MeV

Ch\_Detc: GOES-8/EPS

Ch\_Srce: "...g8\_k0\_ep8....cdf"

Ch\_Indx: 7 (1<sup>st</sup> element of variable E1)

Ch\_Data: EUI\_FLUX (unidirectional integral electron flux)

Ch\_Mult: 1.0

Ch\_Comp: NONE

Ch\_P1Lo: 600.0 (electron energy in keV)

Ch\_P1Hi:  $2 \cdot 10^5$  (electron energy in keV) ????

#### B. GOES Electron Flux > 2 MeV

Ch\_Detc: GOES-8/EPS

Ch\_Srce: "...g8\_k0\_ep8....cdf"

Ch\_Indx: 10 (1<sup>st</sup> element of variable E2)

Ch\_Data: EUI\_FLUX (unidirectional integral electron flux)

Ch\_Mult: 1.0

Ch\_Comp: NONE

Ch\_P1Lo:  $2 \cdot 10^3$  (electron energy in keV)

Ch\_P1Hi:  $2 \cdot 10^5$  (electron energy in keV) ????

#### C. GOES Electron Flux > 4 MeV

Ch\_Detc: GOES-8/EPS

<b>ESWS</b>	Doc. No:	<b>WP 434 – BIRA-IASB</b>
	Issue:	Date: 6/14/00
Space Environment Yellow Pages	Author: MK	Page 23

Ch\_Srce: "...g8\_k0\_ep8....cdf"  
 Ch\_Idx: 13 (1<sup>st</sup> element of variable E1)  
 Ch\_Data: EUI\_FLUX (unidirectional integral electron flux)  
 Ch\_Mult: 1.0  
 Ch\_Comp: NONE  
 Ch\_P1Lo:  $4 \cdot 10^3$  (electron energy in keV)  
 Ch\_P1Hi:  $2 \cdot 10^5$  (electron energy in keV) ) ???

***D. GOES Uncor. Diff. Proton Flux (0.7-4 MeV)***

Ch\_Detc: GOES-8/EPS  
 Ch\_Srce: "...g8\_k0\_ep8....cdf"  
 Ch\_Idx: 16 (1<sup>st</sup> element of variable P1)  
 Ch\_Data: PUD\_FLUX (unidirectional differential proton flux)  
 Ch\_Mult: 1000.0 (MeV<sup>-1</sup> instead of keV<sup>-1</sup>)  
 Ch\_Comp: NONE  
 Ch\_P1Lo: 0.7 (proton energy in MeV)  
 Ch\_P1Hi: 4.0 (proton energy in MeV)

***E. 5-minute average uncorrected P1 channel***

Ch\_Detc: GOES-8/EPS  
 Ch\_Srce: "...G8pchan\_5m.txt"  
 Ch\_Idx: 7  
 Ch\_Data: PUD\_FLUX (unidirectional differential proton flux)  
 Ch\_Mult: 1000.0 (MeV<sup>-1</sup> instead of keV<sup>-1</sup>)  
 Ch\_Comp: NONE  
 Ch\_P1Lo: 0.7 (proton energy in MeV)  
 Ch\_P1Hi: 4.0 (proton energy in MeV)

***F. 5-minute average uncorrected P2 channel***

Ch\_Detc: GOES-8/EPS  
 Ch\_Srce: "...G8pchan\_5m.txt"  
 Ch\_Idx: 8  
 Ch\_Data: PUD\_FLUX (unidirectional differential proton flux)  
 Ch\_Mult: 1000.0 (MeV<sup>-1</sup> instead of keV<sup>-1</sup>)  
 Ch\_Comp: NONE  
 Ch\_P1Lo: 4.0 (proton energy in MeV)  
 Ch\_P1Hi: 9.0 (proton energy in MeV)

***G. 5-minute average uncorrected P3 channel***

Ch\_Detc: GOES-8/EPS  
 Ch\_Srce: "...G8pchan\_5m.txt"  
 Ch\_Idx: 9  
 Ch\_Data: PUD\_FLUX (unidirectional differential proton flux)  
 Ch\_Mult: 1000.0 (MeV<sup>-1</sup> instead of keV<sup>-1</sup>)  
 Ch\_Comp: NONE  
 Ch\_P1Lo: 9.0 (proton energy in MeV)  
 Ch\_P1Hi: 15.0 (proton energy in MeV)

***H. 5-minute average uncorrected P4 channel***

<b>ESWS</b>	Doc. No:	<b>WP 434 – BIRA-IASB</b>
	Issue:	Date: 6/14/00
Space Environment Yellow Pages		Author: MK
		Page 24

Ch\_Detc: GOES-8/EPS  
 Ch\_Srce: "...G8pchan\_5m.txt"  
 Ch\_Indx: 10  
 Ch\_Data: PUD\_FLUX (unidirectional differential proton flux)  
 Ch\_Mult: 1000.0 (MeV<sup>-1</sup> instead of keV<sup>-1</sup>)  
 Ch\_Comp: NONE  
 Ch\_P1Lo: 15.0 (proton energy in MeV)  
 Ch\_P1Hi: 40.0 (proton energy in MeV)

***I. 5-minute average uncorrected P5 channel***

Ch\_Detc: GOES-8/EPS  
 Ch\_Srce: "...G8pchan\_5m.txt"  
 Ch\_Indx: 11  
 Ch\_Data: PUD\_FLUX (unidirectional differential proton flux)  
 Ch\_Mult: 1000.0 (MeV<sup>-1</sup> instead of keV<sup>-1</sup>)  
 Ch\_Comp: NONE  
 Ch\_P1Lo: 40.0 (proton energy in MeV)  
 Ch\_P1Hi: 80.0 (proton energy in MeV)

***J. 5-minute average uncorrected P6 channel***

Ch\_Detc: GOES-8/EPS  
 Ch\_Srce: "...G8pchan\_5m.txt"  
 Ch\_Indx: 12  
 Ch\_Data: PUD\_FLUX (unidirectional differential proton flux)  
 Ch\_Mult: 1000.0 (MeV<sup>-1</sup> instead of keV<sup>-1</sup>)  
 Ch\_Comp: NONE  
 Ch\_P1Lo: 80.0 (proton energy in MeV)  
 Ch\_P1Hi: 165.0 (proton energy in MeV)

***K. 5-minute average uncorrected P7 channel***

Ch\_Detc: GOES-8/EPS  
 Ch\_Srce: "...G8pchan\_5m.txt"  
 Ch\_Indx: 13  
 Ch\_Data: PUD\_FLUX (unidirectional differential proton flux)  
 Ch\_Mult: 1000.0 (MeV<sup>-1</sup> instead of keV<sup>-1</sup>)  
 Ch\_Comp: NONE  
 Ch\_P1Lo: 165.0 (proton energy in MeV)  
 Ch\_P1Hi: 500.0 (proton energy in MeV)

***L. 5-minute average uncorrected P8 channel***

Ch\_Detc: GOES-8/EPS  
 Ch\_Srce: "...G8pchan\_5m.txt"  
 Ch\_Indx: 14  
 Ch\_Data: PUD\_FLUX (unidirectional differential proton flux)  
 Ch\_Mult: 1000.0 (MeV<sup>-1</sup> instead of keV<sup>-1</sup>)  
 Ch\_Comp: NONE  
 Ch\_P1Lo: 350.0 (proton energy in MeV)  
 Ch\_P1Hi: 420.0 (proton energy in MeV)

<b>ESWS</b>	Doc. No:	<b>WP 434 – BIRA-IASB</b>
	Issue:	Date: 6/14/00
Space Environment Yellow Pages	Author: MK	Page 25

***M. 5-minute average uncorrected P9 channel***

Ch\_Detc: GOES-8/EPS  
Ch\_Srce: "...G8pchan\_5m.txt"  
Ch\_Indx: 15  
Ch\_Data: PUD\_FLUX (unidirectional differential proton flux)  
Ch\_Mult: 1000.0 (MeV<sup>-1</sup> instead of keV<sup>-1</sup>)  
Ch\_Comp: NONE  
Ch\_P1Lo: 420.0 (proton energy in MeV)  
Ch\_P1Hi: 510.0 (proton energy in MeV)

***N. 5-minute average uncorrected P10 channel***

Ch\_Detc: GOES-8/EPS  
Ch\_Srce: "...G8pchan\_5m.txt"  
Ch\_Indx: 16  
Ch\_Data: PUD\_FLUX (unidirectional differential proton flux)  
Ch\_Mult: 1000.0 (MeV<sup>-1</sup> instead of keV<sup>-1</sup>)  
Ch\_Comp: NONE  
Ch\_P1Lo: 510.0 (proton energy in MeV)  
Ch\_P1Hi: 700.0 (proton energy in MeV)

***O. 5-minute average uncorrected P11 channel***

Ch\_Detc: GOES-8/EPS  
Ch\_Srce: "...G8pchan\_5m.txt"  
Ch\_Indx: 17  
Ch\_Data: PUD\_FLUX (unidirectional differential proton flux)  
Ch\_Mult: 1000.0 (MeV<sup>-1</sup> instead of keV<sup>-1</sup>)  
Ch\_Comp: NONE  
Ch\_P1Lo: 700.0 (proton energy in MeV)  
Ch\_P1Hi: 1000.0 (proton energy in MeV)

***P. 5-minute average proton flux > 1 MeV***

Ch\_Detc: GOES-8/EPS  
Ch\_Srce: "...G8part\_5m.txt"  
Ch\_Indx: 7  
Ch\_Data: PUI\_FLUX (unidirectional integral proton flux)  
Ch\_Mult: 1.0  
Ch\_Comp: NONE  
Ch\_P1Lo: 1.0 (proton energy in MeV)  
Ch\_P1Hi: 700.0 (proton energy in MeV)

***Q. 5-minute average proton flux > 5 MeV***

Ch\_Detc: GOES-8/EPS  
Ch\_Srce: "...G8part\_5m.txt"  
Ch\_Indx: 8  
Ch\_Data: PUI\_FLUX (unidirectional integral proton flux)  
Ch\_Mult: 1.0  
Ch\_Comp: NONE  
Ch\_P1Lo: 5.0 (proton energy in MeV)

<b>ESWS</b>	Doc. No:	<b>WP 434 – BIRA-IASB</b>
	Issue:	Date: 6/14/00
Space Environment Yellow Pages	Author: MK	Page 26

Ch\_P1Hi: 700.0 (proton energy in MeV)

**R. 5-minute average proton flux > 10 MeV**

Ch\_Detc: GOES-8/EPS  
 Ch\_Srce: "...G8part\_5m.txt"  
 Ch\_Indx: 9  
 Ch\_Data: PUI\_FLUX (unidirectional integral proton flux)  
 Ch\_Mult: 1.0  
 Ch\_Comp: NONE  
 Ch\_P1Lo: 10.0 (proton energy in MeV)  
 Ch\_P1Hi: 700.0 (proton energy in MeV)

**S. 5-minute average proton flux > 30 MeV**

Ch\_Detc: GOES-8/EPS  
 Ch\_Srce: "...G8part\_5m.txt"  
 Ch\_Indx: 10  
 Ch\_Data: PUI\_FLUX (unidirectional integral proton flux)  
 Ch\_Mult: 1.0  
 Ch\_Comp: NONE  
 Ch\_P1Lo: 30.0 (proton energy in MeV)  
 Ch\_P1Hi: 700.0 (proton energy in MeV)

**T. 5-minute average proton flux > 50 MeV**

Ch\_Detc: GOES-8/EPS  
 Ch\_Srce: "...G8part\_5m.txt"  
 Ch\_Indx: 11  
 Ch\_Data: PUI\_FLUX (unidirectional integral proton flux)  
 Ch\_Mult: 1.0  
 Ch\_Comp: NONE  
 Ch\_P1Lo: 50.0 (proton energy in MeV)  
 Ch\_P1Hi: 700.0 (proton energy in MeV)

**U. 5-minute average proton flux > 100 MeV**

Ch\_Detc: GOES-8/EPS  
 Ch\_Srce: "...G8part\_5m.txt"  
 Ch\_Indx: 12  
 Ch\_Data: PUI\_FLUX (unidirectional integral proton flux)  
 Ch\_Mult: 1.0  
 Ch\_Comp: NONE  
 Ch\_P1Lo: 100.0 (proton energy in MeV)  
 Ch\_P1Hi: 700.0 (proton energy in MeV)

**V. 5-minute average electron flux > 0.6 MeV**

Ch\_Detc: GOES-8/EPS  
 Ch\_Srce: "...G8part\_5m.txt"  
 Ch\_Indx: 13  
 Ch\_Data: EUI\_FLUX (unidirectional integral electron flux)  
 Ch\_Mult: 1.0  
 Ch\_Comp: NONE

<b>ESWS</b>	Doc. No:	<b>WP 434 – BIRA-IASB</b>
	Issue:	Date: 6/14/00
Space Environment Yellow Pages	Author: MK	Page 27

Ch\_P1Lo: 600.0 (electron energy in keV)  
Ch\_P1Hi:  $2 \cdot 10^5$  (electron energy in keV) ????

**W. 5-minute average electron flux > 2 MeV**

Ch\_Detc: GOES-8/EPS  
Ch\_Srce: "...G8part\_5m.txt"  
Ch\_Indx: 14  
Ch\_Data: EUI\_FLUX (unidirectional integral electron flux)  
Ch\_Mult: 1.0  
Ch\_Comp: NONE  
Ch\_P1Lo: 2000.0 (electron energy in keV)  
Ch\_P1Hi:  $2 \cdot 10^5$  (electron energy in keV) ????

**X. 5-minute average electron flux > 4 MeV**

Ch\_Detc: GOES-8/EPS  
Ch\_Srce: "...G8part\_5m.txt"  
Ch\_Indx: 15  
Ch\_Data: EUI\_FLUX (unidirectional integral electron flux)  
Ch\_Mult: 1.0  
Ch\_Comp: NONE  
Ch\_P1Lo: 4000.0 (electron energy in keV)  
Ch\_P1Hi:  $2 \cdot 10^5$  (electron energy in keV) ????

**Y. daily proton fluence > 1 MeV**

Ch\_Detc: GOES-8/EPS  
Ch\_Srce: "...DPD.txt"  
Ch\_Indx: 4  
Ch\_Data: PUI\_FLUX (unidirectional integral proton flux)  
Ch\_Mult: 1.0  
Ch\_Comp: NONE  
Ch\_P1Lo: 1.0 (proton energy in MeV)  
Ch\_P1Hi: 700.0 (proton energy in MeV)

**Z. daily proton fluence > 10 MeV**

Ch\_Detc: GOES-8/EPS  
Ch\_Srce: "...DPD.txt"  
Ch\_Indx: 5  
Ch\_Data: PUI\_FLUX (unidirectional integral proton flux)  
Ch\_Mult: 1.0  
Ch\_Comp: NONE  
Ch\_P1Lo: 10.0 (proton energy in MeV)  
Ch\_P1Hi: 700.0 (proton energy in MeV)

**AA. daily proton fluence > 100 MeV**

Ch\_Detc: GOES-8/EPS  
Ch\_Srce: "...DPD.txt"  
Ch\_Indx: 6  
Ch\_Data: PUI\_FLUX (unidirectional integral proton flux)  
Ch\_Mult: 1.0

<b>ESWS</b>	Doc. No:	<b>WP 434 – BIRA-IASB</b>
	Issue:	Date: 6/14/00
Space Environment Yellow Pages	Author: MK	Page 28

Ch\_Comp: NONE  
Ch\_P1Lo: 100.0 (proton energy in MeV)  
Ch\_P1Hi: 700.0 (proton energy in MeV)

**BB. *daily electron fluence > 0.6 MeV***

Ch\_Detc: GOES-8/EPS  
Ch\_Srce: "...DPD.txt"  
Ch\_Indx: 7  
Ch\_Data: EUI\_FLUX (unidirectional integral electron flux)  
Ch\_Mult: 1.0  
Ch\_Comp: NONE  
Ch\_P1Lo: 600.0 (electron energy in keV)  
Ch\_P1Hi: 2. 10<sup>5</sup> (electron energy in keV) ????

**CC. *daily electron fluence > 2 MeV***

Ch\_Detc: GOES-8/EPS  
Ch\_Srce: "...DPD.txt"  
Ch\_Indx: 8  
Ch\_Data: EUI\_FLUX (unidirectional integral electron flux)  
Ch\_Mult: 1.0  
Ch\_Comp: NONE  
Ch\_P1Lo: 2000.0 (electron energy in keV)  
Ch\_P1Hi: 2. 10<sup>5</sup> (electron energy in keV) ????

### 1.4.5 Spacecraft Ephemeris

For each space mission, a pseudo sensor is defined for all the location and attitude data of the corresponding spacecraft. Pseudo parameters are also introduced in the SE parameter catalogue accordingly. For instance:

Md\_Name: SAT\_LOC  
Md\_Desc: Spacecraft location (support data)  
Md\_Unit: arbitrary unit  
Md\_NbrP: 0  
Md\_DtaT: POSITION

Where POSITION is a data type, the components of which include:

ALT: Geodetic altitude (in km)  
GDLAT: Geodetic latitude (in degrees)  
ELONG: East Longitude (in degrees)  
GEOLAT: Geocentric latitude (in degrees)  
GEORAD: Geocentric radius (in km)  
GEOX: GEO x-coordinate (in km)  
GEOY: GEO y-coordinate (in km)  
GEOZ: GEO z-coordinate (in km)  
GSEX: GSE, GSEQ and GSM x-coordinate (in km)  
GSEY: GSE y-coordinate (in km)  
GSEZ: GSE z-coordinate (in km)  
GSMY: GSM y-coordinate (in km)

<b>ESWS</b>	Doc. No:	<b>WP 434 – BIRA-IASB</b>
	Issue:	Date: 6/14/00
Space Environment Yellow Pages	Author: MK	Page 29

GSMZ: GSM z-coordinate (in km)

The pseudo sensor for the GOES-8 location can then be defined as: (see Table 1-J)

De\_Name: GOES-8/loc  
De\_Desc: GOES-8 location and attitude data  
De\_Info: GOES-8 is a NASA-developed NOAA-operated tri-axis stabilized spacecraft in geostationary orbit launched on 13 April 2000 and parked about 75 degrees West of longitude.  
De\_Nchn: 0  
De\_Head: Mr. Arthur F. Obenschain  
De\_Orga: NASA Goddard Space Flight Center  
De\_Emai: robensch@pop400.gsfc.nasa.gov  
De\_Addr: Code 430, Greenbelt, MD 20771, USA  
De\_Home: <http://www.gsfc.nasa.gov/>  
De\_Help: <http://rsd.gsfc.nasa.gov/goesb/chesters/web/text/databook/section01.pdf>  
De\_Mcat: 94-022A  
De\_Refe:  
De\_Tres: 10.2  
De\_Keyw:

The generic files related to the GOES location are:

- 1. GOES 8 Magnetometer Key Parameters on the Coordinated Data Analysis Web FTP site** (see Section 1.4.3)
- 2. GOES 8 Energetic Particle Key Parameters on the Coordinated Data Analysis Web FTP site** (see Section 1.4.4)
- 3. GOES Position Summary on SPIDR web site** (see Table 1-I)

Fi\_Desc:  
Fi\_Serv: SPIDR  
Fi\_Durl: <http://julius.ngdc.noaa.gov:8080/production/html/GOES/satpos.txt>  
Fi\_Epoc: MJD1950-PRESENT  
Fi\_Star: ????? (2 December 1995)  
Fi\_Stop: -1.0 (yesterday)  
Fi\_Ncol: -1 (file not organized in columns)  
Fi\_Tres: 86400.0 (daily values)

Note that both first files includes exactly the same data. For the sake of clarity, only the second one (GOES-8/EPS) is referred hereafter. The pseudo channels associated to spacecraft location are are:

**A. GOES-8 Geocen Lat.**

Ch\_Detc: GOES-8/loc  
Ch\_Srce: "...g8\_k0\_ep8....cdf"  
Ch\_Indx: 37 (1<sup>st</sup> element of variable SC\_pos\_ll)  
Ch\_Data: SAT\_LOC  
Ch\_Comp: GEOLAT

**B. GOES-8 E Longitude**

Ch\_Detc: GOES-8/loc  
Ch\_Srce: "...g8\_k0\_ep8....cdf"

<b>ESWS</b>	Doc. No:	<b>WP 434 – BIRA-IASB</b>
	Issue:	Date: 6/14/00
Space Environment Yellow Pages		Author: MK
		Page 30

Ch\_Indx: 38 (2<sup>nd</sup> element of variable SC\_pos\_ll)

Ch\_Data: SAT\_LOC

Ch\_Comp: ELONG

**C. GOES-8 Radius**

Ch\_Detc: GOES-8/loc

Ch\_Srce: "...g8\_k0\_ep8....cdf"

Ch\_Indx: 39 (3<sup>rd</sup> element of variable SC\_pos\_ll)

Ch\_Data: SAT\_LOC

Ch\_Comp: GEORAD

**D. GOES-8 X GEO**

Ch\_Detc: GOES-8/loc

Ch\_Srce: "...g8\_k0\_ep8....cdf"

Ch\_Indx: 40 (1<sup>st</sup> element of variable SC\_pos\_eo)

Ch\_Data: SAT\_LOC

Ch\_Comp: GEOX

**E. GOES-8 Y GEO**

Ch\_Detc: GOES-8/loc

Ch\_Srce: "...g8\_k0\_ep8....cdf"

Ch\_Indx: 41 (2<sup>nd</sup> element of variable SC\_pos\_eo)

Ch\_Data: SAT\_LOC

Ch\_Comp: GEOY

**F. GOES-8 Z GEO**

Ch\_Detc: GOES-8/loc

Ch\_Srce: "...g8\_k0\_ep8....cdf"

Ch\_Indx: 42 (3<sup>rd</sup> element of variable SC\_pos\_eo)

Ch\_Data: SAT\_LOC

Ch\_Comp: GEOZ

**G. GOES-8 X GSE**

Ch\_Detc: GOES-8/loc

Ch\_Srce: "...g8\_k0\_ep8....cdf"

Ch\_Indx: 43 (1<sup>st</sup> element of variable SC\_pos\_se)

Ch\_Data: SAT\_LOC

Ch\_Comp: GSEX

**H. GOES-8 Y GSE**

Ch\_Detc: GOES-8/loc

Ch\_Srce: "...g8\_k0\_ep8....cdf"

Ch\_Indx: 44 (2<sup>nd</sup> element of variable SC\_pos\_se)

Ch\_Data: SAT\_LOC

Ch\_Comp: GSEY

**I. GOES-8 Z GSE**

Ch\_Detc: GOES-8/loc

Ch\_Srce: "...g8\_k0\_ep8....cdf"

Ch\_Indx: 45 (3<sup>rd</sup> element of variable SC\_pos\_se)

Ch\_Data: SAT\_LOC

<b>ESWS</b>	Doc. No:	<b>WP 434 – BIRA-IASB</b>
	Issue:	Date: 6/14/00
Space Environment Yellow Pages	Author: MK	Page 31

Ch\_Comp: GSEZ

**J. GOES-8 X GSM**

Ch\_Detc: GOES-8/loc  
 Ch\_Srce: "...g8\_k0\_ep8....cdf"  
 Ch\_Indx: 46 (1<sup>st</sup> element of variable SC\_pos\_sm)  
 Ch\_Data: SAT\_LOC  
 Ch\_Comp: GSEX (same as X GSE)

**K. GOES-8 Y GSM**

Ch\_Detc: GOES-8/loc  
 Ch\_Srce: "...g8\_k0\_ep8....cdf"  
 Ch\_Indx: 47 (2<sup>nd</sup> element of variable SC\_pos\_sm)  
 Ch\_Data: SAT\_LOC  
 Ch\_Comp: GSMY

**L. GOES-8 Z GSM**

Ch\_Detc: GOES-8/loc  
 Ch\_Srce: "...g8\_k0\_ep8....cdf"  
 Ch\_Indx: 48 (3<sup>rd</sup> element of variable SC\_pos\_sm)  
 Ch\_Data: SAT\_LOC  
 Ch\_Comp: GSMZ

**M. GOES-8 Longitude from SPIDR**

Ch\_Detc: GOES-8/loc  
 Ch\_Srce: "...satpos.txt"  
 Ch\_Indx: 8 (index of the GOES satellite)  
 Ch\_Data: SAT\_LOC  
 Ch\_Comp: ELONG

### 1.4.6 Graphical Summary

